

# INDELAC

## CONTROLS, INC.

Safe & Secure Series Electric Actuator  
with Internal Battery Back-up

Installation, Operation &  
Maintenance Manual

*For Use with:*  
*SNS20 & SNS28 Models (R1)*

*Additional supplements may be needed for selected optional equipment including, but not limited to models with: timers, speed controllers & remote/off/local controls.*

MSNS2-250812

REVISED: AUG 2025

TELEPHONE: +1-859-727-7890  
TOLL FREE: +1-800-662-9424  
FAX: +1-859-727-4070

SHIPPING ADDRESS: 6810 POWERLINE DR.-FLORENCE, KY. 41042

For a digital copy of this manual, access to training videos, access to 3D product renderings,  
or to request additional support

VISIT OUR WEBSITE AT [WWW.INDELAC.COM](http://WWW.INDELAC.COM)

**INTRODUCTION:**

Thank you for selecting Indelac Controls, Inc. (ICI) for your valve or damper automation requirement. We at ICI are proud of our products and feel confident they will meet or exceed your expectations of quality and reliability.

Every precaution has been taken to insure that your equipment will arrive undamaged; however, accidents do occur. Therefore, the first thing you must do upon receipt of your package is to inspect it for damage. If the box is damaged there is a possibility that the equipment inside the box may be damaged as well. If this is the case **YOU MUST FILE A CLAIM** with the delivering **CARRIER**. All shipments are **F.O.B.** our factory and it is **YOUR RESPONSIBILITY** to file a claim for damages.

**STORAGE:**

If the actuators are scheduled for installation at a later date:

1. Store off the floor in a clean dry area.
2. Store in a climate controlled building.
3. See the Battery Maintenance Section in this Manual for proper battery storage.

**FOR FUTURE REFERENCE RECORD:**

1. Actuator model number \_\_\_\_\_
2. Actuator enclosure type NEMA 4\_\_, NEMA 4X\_\_, NEMA 7\_\_, NEMA 4 & 7\_\_
3. Actuator output torque: 2000 or 2800 LB-IN
4. Motor characteristics, Voltage\_\_\_\_\_ AC or DC\_\_\_\_\_ HZ\_\_\_\_\_
5. Actuator serial number \_\_\_\_\_
6. Date of installation \_\_\_\_\_ Put into operation \_\_\_\_\_
7. Valve Data:
  - 7a. Manufacturer \_\_\_\_\_
  - 7b. Style & fig. No. \_\_\_\_\_
  - 7c. Size \_\_\_\_\_
  - 7d. End connection \_\_\_\_\_
  - 7e. Material of construction, Body \_\_\_\_\_ Stem & ball \_\_\_\_\_
  - 7f. Brake away torque \_\_\_\_\_ LB-IN @ \_\_\_\_\_ PSI
  - 7g. Other helpful data \_\_\_\_\_

**MEDIA:**

1. System media \_\_\_\_\_
2. Temperature, \_\_\_\_\_ (deg. F.) Maximum, \_\_\_\_\_. Minimum, \_\_\_\_\_.
3. Pressure \_\_\_\_\_ PSI

*\*It is important to pay attention to all of the actuator specifications relative to the valve specifications and system requirements. If the actuator is not properly sized for the valve and application, the life will be shortened or it may not work at all.*

**TABLE OF CONTENTS:**

|   |    |
|---|----|
| TOOLS REQUIRED:_____                                    | 4  |
| BOLT TORQUE CHART:_____                                 | 4  |
| PRODUCT DESCRIPTION:_____                               | 5  |
| UNIT SPECIFICATIONS:_____                               | 6  |
| MECHANICAL MOUNTING:_____                               | 7  |
| CUSTOMER ELECTRICAL CONNECTIONS & WIRING DIAGRAMS:_____ | 8  |
| SET-UP FOR STANDARD & TWO WIRE ACTUATORS:_____          | 15 |
| SET-UP FOR MODULATING ACTUATORS:_____                   | 19 |
| STANDARD ACTUATOR OPERATION:_____                       | 22 |
| TWO WIRE ACTUATOR OPERATION:_____                       | 23 |
| MODULATING ACTUATOR OPERATION:_____                     | 24 |
| MODULATING BOARD CALIBRATION PROCEDURE:_____            | 25 |
| EXTERNAL FEATURES & CONNECTIONS:_____                   | 28 |
| BATTERY OPERATION, INSTALLATION & MAINTENANCE:_____     | 30 |
| MOTOR OVERLOAD - FUSE:_____                             | 31 |
| MECHANICAL OVERLOAD:_____                               | 31 |
| SPARE PARTS:_____                                       | 31 |
| OPTIONAL AUXILIARY SWITCH OPERATION & INSTALL:_____     | 32 |
| OPTIONAL HEATER:_____                                   | 34 |
| OPTIONAL MECHANICAL BRAKE:_____                         | 34 |
| NEMA 7 ENCLOSURES:_____                                 | 36 |
| MANUAL REVISIONS:_____                                  | 37 |
| TROUBLESHOOTING:_____                                   | 38 |
| TECHNICAL ASSISTANCE & NOTES:_____                      | 37 |
| NOTES:_____   | 40 |

**TOOLS REQUIRED:**

*\*ADDITIONAL TOOLS WILL BE REQUIRED FOR THE SCREWS TO MOUNT THE VALVE TO THE ACTUATOR.*

**SNS20C & SNS28C SERIES**

|                       |                                  |
|-----------------------|----------------------------------|
| Cover Screws          | 7/16" Socket                     |
| Terminal Strip Screws | 3/16" Wide Flat Head Screwdriver |
| Cam Set Screw         | 5/64" Allen Wrench               |
| Mounting Pad Screws   | 9/16" Socket                     |

**SUGGESTED MAXIMUM TORQUE VALUES FOR FASTENERS (IN-LBS.)**

| SCREW SIZE | LOW CARBON STEEL | 18-8 SS | 316 SS | ALUMINUM |
|------------|------------------|---------|--------|----------|
| 2-56       | 2.2              | 2.5     | 2.6    | 1.4      |
| 4-40       | 4.7              | 5.2     | 5.5    | 2.9      |
| 6-32       | 9                | 10      | 10     | 5        |
| 8-32       | 18               | 20      | 21     | 10       |
| 10-24      | 21               | 23      | 24     | 13       |
| 10.32      | 30               | 32      | 33     | 19       |
| ¼-20       | 65               | 75      | 79     | 45       |
| 5/16-18    | 129              | 132     | 138    | 80       |
| 3/8-16     | 212              | 236     | 247    | 143      |
| ½-13       | 465              | 517     | 542    | 313      |
| 5/8-11     | 1000             | 1110    | 1160   | 715      |

**\*\*Wiring Terminal Block Screws – tighten to 3.6 in/lbs. torque!**



**SNS 2000 Series Actuator**

**PRODUCT DESCRIPTION:**

The SNS20C – 28C Safe & Secure Series Actuator is a quarter turn Open/Close Actuator with Battery Backup Power – ***ALL IN ONE!*** No more mounting a separate Fail Safe Unit to provide power in case of external power failure. The actuator's internal battery will provide power to the motor to CLOSE or OPEN the valve. The actuator can be configured in the field for FAIL OPEN or FAIL CLOSE.

This series of actuator can operate loads up to 2000 in/lbs. or 2800 in/lbs. These actuators can be ordered to operate on input voltages of 115vac/230vac, 24vac/24vdc or 12vdc and are enclosed in a SINGLE standard "L" series NEMA 4, NEMA 4X or NEMA 7 style housing.

Switching from external power to battery power is seamless – when the external power source fails, the internal transfer circuit switches to battery power automatically without any operator intervention. Depending on the fail position setting that the operator has pre-selected for the actuator, the unit will drive the valve to that position. Once the external power is restored, the actuator will automatically switch back to external power, and the battery will begin to re-charge automatically! The actuator will then return to its last position before the power had failed.

This unit is available as a Standard OPEN/CLOSE Actuator or with the Modulating Option for precise valve position control using 4-20mA, 0-10V or 1-5V external input signal. Position feedback is available for both the standard and the modulating models.

A variety of other optional features are available for these actuators including but not limited to: Auxiliary Limit Switches, Mechanical Friction Brake, Additional Conduit Entries, Mechanical Stops, Temperature and Condensation Controls. *Speed Controls & Timers are available mounted in a separate enclosure.*

**WARNING!**

**THIS ACTUATOR IS INTENDED TO BE USED AS DESCRIBED IN THIS MANUAL BY INDELAC CONTROLS. IF USED FOR ANY OTHER PURPOSES OTHER THAN SPECIFIED HERE, SEVERE DAMAGE COULD OCCUR TO THIS PRODUCT AND ANY OTHER PRODUCTS CONNECTED TO IT.**

**UNIT SPECIFICATIONS:**

| Input Voltage  | 230VAC        | 115VAC        | 24VDC                         | 12VDC                         |
|--|---------------|---------------|-------------------------------|-------------------------------|
|  | SNS20 / SNS28 | SNS20 / SNS28 | SNS20 / SNS28                 | SNS20 / SNS28                 |
| Full Load Amps   | 0.75          | 1.25          | 4.5 / 5.2                     | 6.6 / 9.0                     |
| Locked Rotor Amps  | 1.2           | 2.38          | 24                            | 48                            |
| Motor Duty Cycle<br>(at 100% ambient temperature @ rated torque) | 100%          | 100%          | 100%                          | 100%                          |
| Power, Maximum Watts   | 173           | 150           | 108 / 125                     | 80 / 108                      |
| Minimum Mains Wire AWG<br>(300V @ 105°C)                         | 18 AWG        | 18 AWG        | 18 AWG                        | 16 AWG                        |
| Maximum Mains Wire AWG<br>(300V @ 105°C)                         | 12 AWG        | 12 AWG        | 12 AWG<br>(Max Run = 60 Feet) | 12 AWG<br>(Max Run = 17 Feet) |

|  |   |
|--|---|
| <b>Enclosure rating:</b>               | NEMA 4 Standard; NEMA 4X & NEMA 7 also available                      |
| <b>Standard Actuator Torque:</b>       | <b>SNS20</b> = 2000 in/lbs.<br><b>SNS28</b> = 2800 in/lbs.            |
| <b>Cycle Time:</b>                     | <b>SNS20</b> = 12 seconds / 90°<br><b>SNS28</b> = 14 seconds / 90°    |
| <b>Weight:</b>                         | 40 Lbs.   |
| <b>Mounting Pad:</b>                   | ISO 5211 F10 BC 4.015"  |
| <b>Incoming Power Fuse:</b>            | TR5 Pico Fuse, 250V / 10A   |
| <b>Motor Fuse:</b>                     | 10A Glass Cartridge, Slow Blow 5x20mm                                 |
| <b>Optional Heater Power:</b>          | Add 20 Watts for optional heater                                      |
| <b>Position Indication:</b>            | Dome Style Visual Indicator   |
| <b>Battery:</b>                        | 12vdc, 1.4Ahr Sealed Lead Acid (SLA), Rechargeable                    |
| <b>Battery Recharge Time:</b>          | Approximately 8-10 Hours  |
| <b>Battery Life on Trickle Charge:</b> | 3-4 years   |
| <b>Auxiliary Switch Rating:</b>        | Dry Contact, 10 Amps @ 250vac - Maximum                               |
| <b>Input Signal Contact Rating:</b>    | 12vdc @ 0.5A minimum ( <b>Dry Contact Only</b> – NO External Voltage) |
| <b>Operating Temperatures:</b>         | -40°F to 150°F (-40°C to 65°C); <b>Heater required below 0°F</b>      |

**MECHANICAL MOUNTING:**

The Safe & Secure Actuator can be direct mounted to any valve using the standard ISO 5211 F10 Output. See the drawing below for the actuator output mounting dimensions for valves requiring mounting hardware.

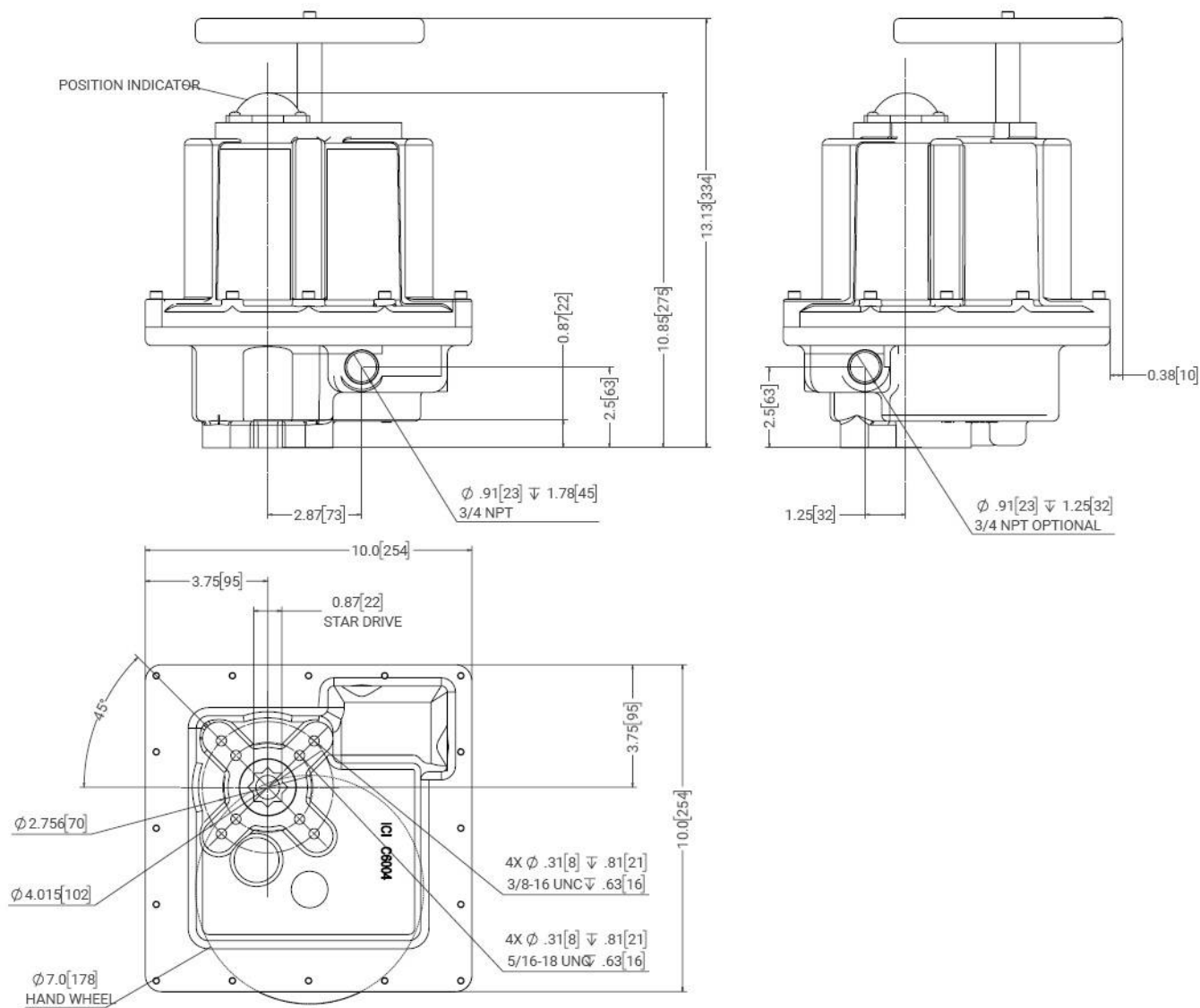

**CUSTOMER ELECTRICAL CONNECTIONS FOR STANDARD OPEN/CLOSE:**

All customer electrical connections are done per the below wiring diagrams. Incoming power should be wired using the wire gauge chart in the Specifications Section on Page 6. Control signal wiring may be 18awg or larger for direction control. All wiring is to be completed through the 3/4" NPT conduit opening using the appropriate conduit – **Refer to your local electrical codes – Class 1 Wiring. Remove the Plastic Conduit Hole Plug from the Conduit Entry Hole and Discard – this is a temporary protector for shipping only.** Next, remove the actuator cover by loosening the cover screws and pulling straight up on the cover to complete the wiring and set-up. Assure that all power is DE-ENERGIZED when making the wiring connections. Connect the Main Power to the actuator per the appropriate wiring diagram below. Do not energize power to the actuator until the set up steps have been completed. When re-installing the actuator cover, pay close attention to the wiring and make sure that none of the wires get pinched or damaged.

**! WARNING!**

**PAY CLOSE ATTENTION TO THE WIRING DIAGRAMS WHEN CONNECTING THE INPUT POWER TO THE ACTUATOR. IMPROPER POWER CONNECTION CAN RESULT IN DAMAGE TO THE ACTUATOR OR SERIOUS INJURY TO THE INSTALLER.**

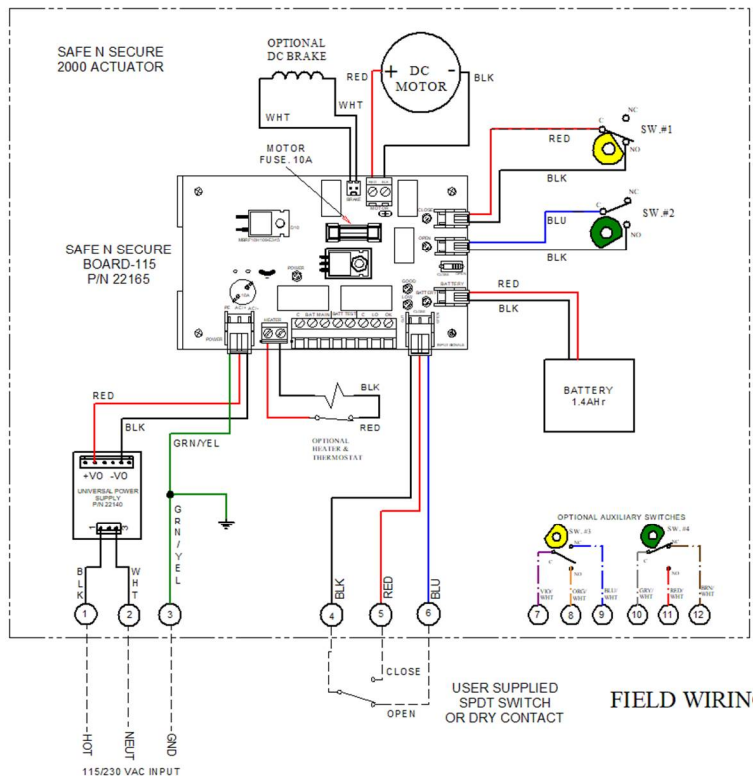

USE STABILIZER BRACKET WITH 4 OR MORE SWITCHES IN A STACK

OPEN AUXILIARY SWITCH  
 CLOSE AUXILIARY SWITCH  
 OPEN LIMIT SWITCH  
 CLOSE LIMIT SWITCH  
 SWITCH LAYOUT

ACTUATOR SHOWN IN OPEN POSITION

**NOTES:**

- 1) INPUT POWER SOURCE TO BE 115/230VAC @ 2.0A MINIMUM
- 2) FUSE ON SNS BOARD IS SLOW BLOW, TRJ PLUG IN 10.0A, 250V
- 3) UNIT IS SHIPPED WITHOUT THE BATTERY PLUGGED IN. AFTER INSTALLING UNIT AND CONNECTING INCOMING POWER, PLUG THE 2 PIN BATTERY CONNECTOR INTO THE 2 PIN HEADER ON THE BOARD (J2)
- 4) CAMS FOR LIMIT SWITCHES ARE PRESET AT THE FACTORY. TO INCREASE OR DECREASE VALVE MOTION, SLIGHTLY ADJUST THE OPEN AND CLOSE CAMS.
- 5) THE "FAIL" CONDITION IS SET PER THE SLIDE SWITCH ON THE SNS BOARD FOR FAIL OPEN OR FAIL CLOSE. USER IS TO SET THE "FAIL" POSITION SWITCH PRIOR TO APPLYING POWER TO THE UNIT.
- 6) WHEN INCOMING POWER IS PRESENT, BLUE LED WILL BE LIT AND ACTUATOR RUNS OFF OF INCOMING POWER. WHEN INCOMING POWER FAILS, BLUE LED WILL TURN OFF AND THE YELLOW BATTERY LED WILL LIGHT - ACTUATOR WILL MOVE TO THE "FAIL" POSITION 1 TIME AND STAY THERE UNTIL POWER IS RESTORED.
- 7) RED LED WILL LIGHT WHEN BATTERY VOLTAGE GETS TOO LOW. GREEN LED WILL LIGHT WHEN BATTERY VOLTAGE IS ABOVE 10.5VDC.
- 8) DRY CONTACTS ARE PROVIDED TO INDICATE BATTERY STATUS AND INCOMING POWER STATUS. BATTERY STATUS CAN BE CHECKED WITH THE INCOMING POWER ON BY SHORTING THE 2 BATT TEST POINTS J7-2 & J10-1 MOMENTARILY.
- 9) CONTROL SIGNAL IS TO BE A DRY CONTACT SWITCH OR RELAY CONTACT ONLY! DO NOT APPLY VOLTAGE TO TERMINALS #4, #5 & #6!

**115/230VAC SNS2000 STANDARD OPEN/CLOSE WIRING DIAGRAM**

W200708

**CUSTOMER ELECTRICAL CONNECTIONS FOR STANDARD OPEN/CLOSE:**

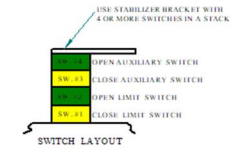
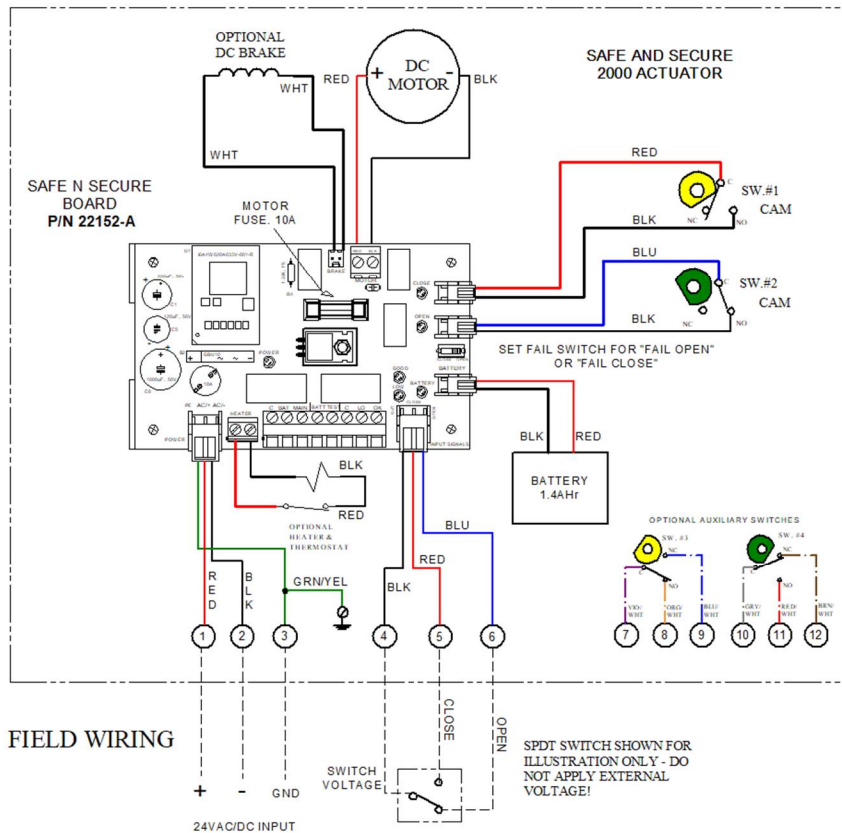

ACTUATOR SHOWN IN OPEN POSITION

- NOTES:**
- 1) INPUT POWER SOURCE TO BE 24VAC OR 24VDC @ 9.0A MINIMUM.
  - 2) FUSE ON SNS BOARD IS SLOW BLOW, TR5 PLUG IN 10.0A, 250V.
  - 3) UNIT IS SHIPPED WITHOUT THE BATTERY PLUGGED IN. AFTER INSTALLING UNIT AND CONNECTING INCOMING POWER, PLUG THE 2 PIN BATTERY CONNECTOR INTO THE 2 PIN HEADER ON THE BOARD (J2).
  - 4) CAMS FOR LIMIT SWITCHES ARE PRESET AT THE FACTORY. TO INCREASE OR DECREASE VALVE MOTION, SLIGHTLY ADJUST THE OPEN AND CLOSE CAMS.
  - 5) THE "FAIL" CONDITION IS SET PER THE SLIDE SWITCH ON THE SNS BOARD FOR FAIL OPEN OR FAIL CLOSE. USER IS TO SET THE "FAIL" POSITION SWITCH PRIOR TO APPLYING POWER TO THE UNIT.
  - 6) WHEN INCOMING POWER IS PRESENT, BLUE LED WILL BE LIT AND ACTUATOR RUNS OFF OF INCOMING POWER. WHEN INCOMING POWER FAILS, BLUE LED WILL TURN OFF AND THE YELLOW BATTERY LED WILL LIGHT - ACTUATOR WILL MOVE TO THE "FAIL" POSITION 1 TIME AND STAY THERE UNTIL POWER IS RESTORED.
  - 7) RED LED WILL LIGHT WHEN BATTERY VOLTAGE GETS TOO LOW. GREEN LED WILL LIGHT WHEN BATTERY VOLTAGE IS ABOVE 10.5VDC.
  - 8) DRY CONTACTS ARE PROVIDED TO INDICATE BATTERY STATUS AND INCOMING POWER STATUS. BATTERY STATUS CAN BE CHECKED WITH THE INCOMING POWER ON BY SHORTING THE 2 BATT TEST POINTS J7-2 & J10-1 MOMENTARILY.
  - 9) CONTROL SIGNAL IS TO BE A DRY CONTACT SWITCH OR RELAY CONTACT ONLY! DO NOT APPLY VOLTAGE TO TERMINALS #4, #5 & #6!

W200628

**24VAC/DC SNS2000 STANDARD OPEN/CLOSE WIRING DIAGRAM**

**NOTE:** For all wiring, make sure the connectors and wires are fully seated after making all wiring connections.

**CUSTOMER ELECTRICAL CONNECTIONS FOR STANDARD OPEN/CLOSE:**

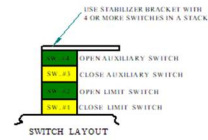
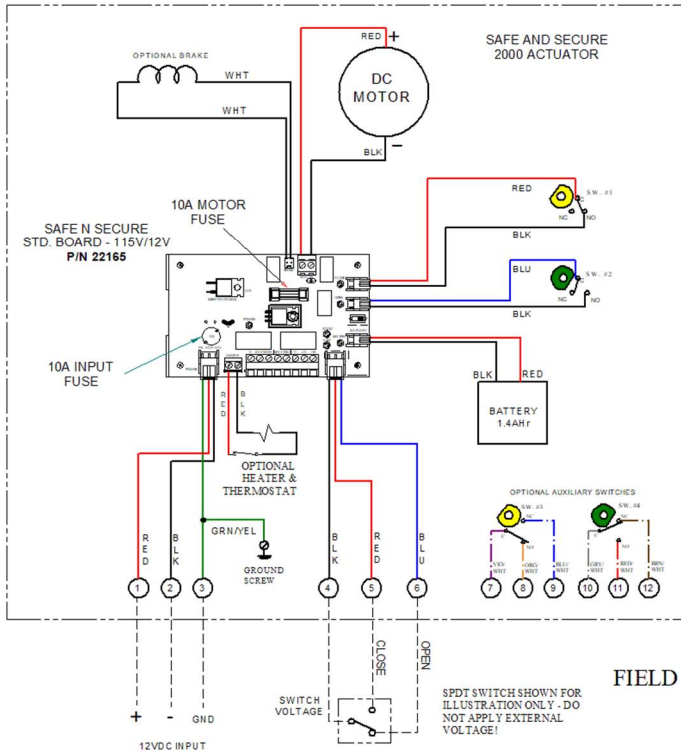

ACTUATOR SHOWN IN OPEN POSITION

**NOTES:**

- 1) INPUT POWER SOURCE TO BE 12VADC @ 10.0A MINIMUM.
- 2) FUSE ON SNS BOARD IS SLOW BLOW, TR5 PLUG IN 10.0A, 250V.
- 3) UNIT IS SHIPPED WITHOUT THE BATTERY PLUGGED IN. AFTER INSTALLING UNIT AND CONNECTING INCOMING POWER, PLUG THE 2 PIN BATTERY CONNECTOR INTO THE 2 PIN HEADER ON THE BOARD (J2).
- 4) CAMS FOR LIMIT SWITCHES ARE PRESET AT THE FACTORY. TO INCREASE OR DECREASE VALVE MOTION, SLIGHTLY ADJUST THE OPEN AND CLOSE CAMS.
- 5) THE "FAIL" CONDITION IS SET PER THE SLIDE SWITCH ON THE SNS BOARD FOR FAIL OPEN OR FAIL CLOSE. USER IS TO SET THE "FAIL" POSITION SWITCH PRIOR TO APPLYING POWER TO THE UNIT.
- 6) WHEN INCOMING POWER IS PRESENT, BLUE LED WILL BE LIT AND ACTUATOR RUNS OFF OF INCOMING POWER. WHEN INCOMING POWER FAILS, BLUE LED WILL TURN OFF AND THE YELLOW BATTERY LED WILL LIGHT. ACTUATOR WILL MOVE TO THE "FAIL" POSITION 1 TIME AND STAY THERE UNTIL POWER IS RESTORED.
- 7) RED LED WILL LIGHT WHEN BATTERY VOLTAGE GETS TOO LOW. GREEN LED WILL LIGHT WHEN BATTERY VOLTAGE IS ABOVE 10.5VDC.
- 8) DRY CONTACTS ARE PROVIDED TO INDICATE BATTERY STATUS AND INCOMING POWER STATUS. BATTERY STATUS CAN BE CHECKED WITH THE INCOMING POWER ON BY SHORTING THE 2 BATT TEST POINTS J7-2 & J10-1 MOMENTARILY.
- 9) CONTROL SIGNAL IS TO BE A DRY CONTACT SWITCH OR RELAY CONTACT ONLY! DO NOT APPLY VOLTAGE TO TERMINALS #4, #5 & #6!

FIELD WIRING

W200707

**12VDC SNS2000 STANDARD OPEN/CLOSE WIRING DIAGRAM**

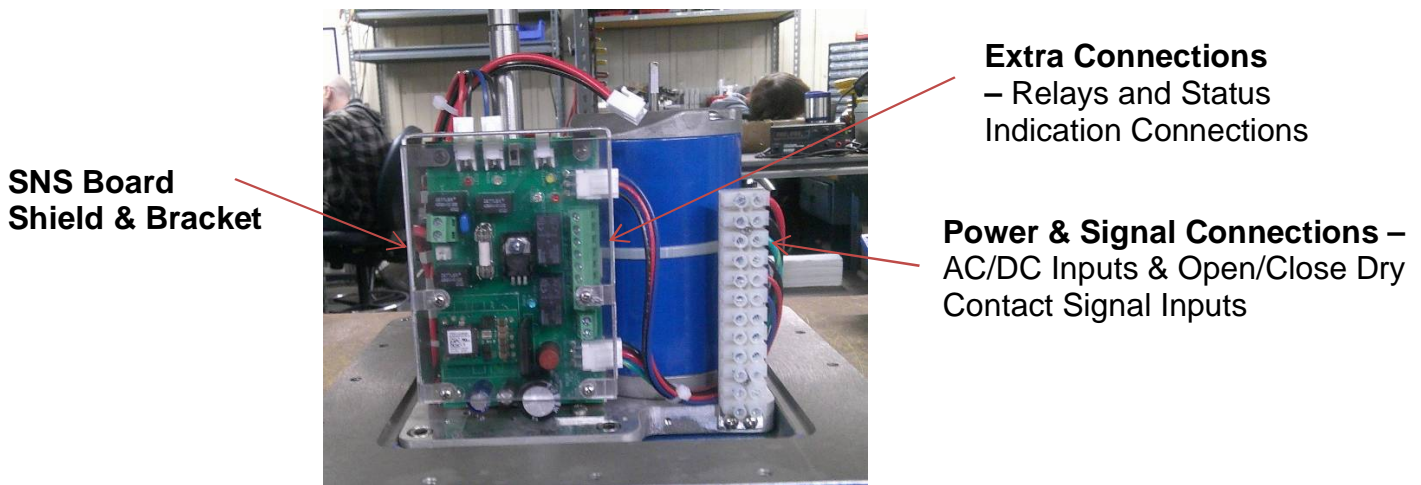

**Customer Connections, Board Connector View**

**CUSTOMER ELECTRICAL CONNECTIONS FOR TWO WIRE OPEN/CLOSE:**

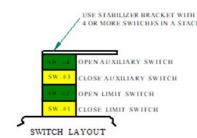
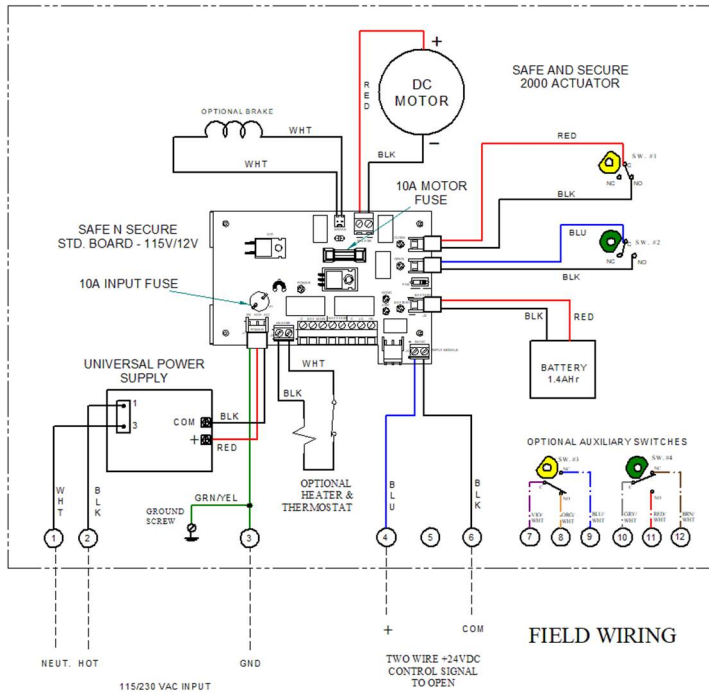

ACTUATOR SHOWN IN OPEN POSITION

- NOTES:**
- 1) INPUT POWER SOURCE TO BE 115/230VAC @ 2.0A MINIMUM
  - 2) FUSE ON SNS BOARD IS SLOW BLOW, TR5 PLUG IN 10.0A, 250V.
  - 3) UNIT IS SHIPPED WITHOUT THE BATTERY PLUGGED IN. AFTER INSTALLING UNIT AND CONNECTING INCOMING POWER, PLUG THE 2 PIN BATTERY CONNECTOR INTO THE 2 PIN HEADER ON THE BOARD (J2).
  - 4) CAMS FOR LIMIT SWITCHES ARE PRESET AT THE FACTORY. TO INCREASE OR DECREASE VALVE MOTION, SLIGHTLY ADJUST THE OPEN AND CLOSE CAMS.
  - 5) THE "FAIL" CONDITION IS SET PER THE SLIDE SWITCH ON THE SNS BOARD FOR FAIL OPEN OR FAIL CLOSE. USER IS TO SET THE "FAIL" POSITION SWITCH PRIOR TO APPLYING POWER TO THE UNIT.
  - 6) WHEN INCOMING POWER IS PRESENT, BLUE LED WILL BE LIT AND ACTUATOR RUNS OFF OF INCOMING POWER. WHEN INCOMING POWER FAILS, BLUE LED WILL TURN OFF AND THE YELLOW BATTERY LED WILL LIGHT - ACTUATOR WILL MOVE TO THE "FAIL" POSITION 1 TIME AND STAY THERE UNTIL POWER IS RESTORED.
  - 7) RED LED WILL LIGHT WHEN BATTERY VOLTAGE GETS TOO LOW. GREEN LED WILL LIGHT WHEN BATTERY VOLTAGE IS ABOVE 10.5VDC.
  - 8) DRY CONTACTS ARE PROVIDED TO INDICATE BATTERY STATUS AND INCOMING POWER STATUS. BATTERY STATUS CAN BE CHECKED WITH THE INCOMING POWER ON BY SHORTING THE 2 BATT TEST POINTS J7-2 & J10-1 MOMENTARILY.
  - 9) WHEN 115VAC/230VAC MAINS POWER IS APPLIED TO THE ACTUATOR, THE MOTOR WILL DRIVE TO THE "CLOSE" POSITION. TO DRIVE THE ACTUATOR TO THE "OPEN" POSITION, APPLY +24VDC AND GND TO TERMINALS #4 & #6 AS SHOWN. WHEN THIS +24VDC SIGNAL VOLTAGE IS REMOVED, THE ACTUATOR WILL DRIVE BACK TO THE "CLOSE" POSITION.
  - 10) WHEN EITHER THE INCOMING POWER OR THE CONTROL SIGNAL FAILS, THE ACTUATOR WILL DRIVE TO THE CLOSE POSITION, IF THE FAIL SWITCH IS SET FOR "CLOSE".

W240221

**115VAC/230VAC SNS2000 TWO WIRE OPEN/CLOSE WIRING DIAGRAM**

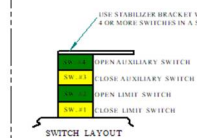
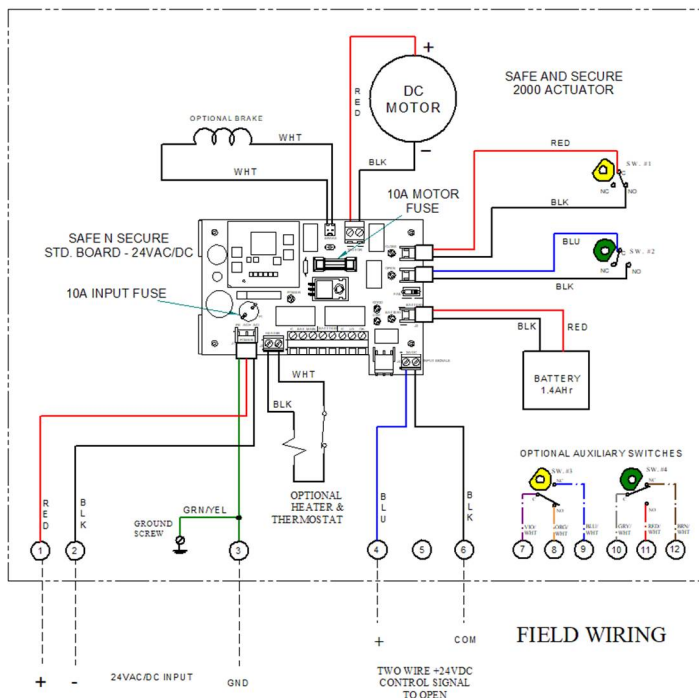

ACTUATOR SHOWN IN OPEN POSITION

- NOTES:**
- 1) INPUT POWER SOURCE TO BE 24VAC/DC @ 9.0A MINIMUM
  - 2) FUSE ON SNS BOARD IS SLOW BLOW, TR5 PLUG IN 10.0A, 250V.
  - 3) UNIT IS SHIPPED WITHOUT THE BATTERY PLUGGED IN. AFTER INSTALLING UNIT AND CONNECTING INCOMING POWER, PLUG THE 2 PIN BATTERY CONNECTOR INTO THE 2 PIN HEADER ON THE BOARD (J2).
  - 4) CAMS FOR LIMIT SWITCHES ARE PRESET AT THE FACTORY. TO INCREASE OR DECREASE VALVE MOTION, SLIGHTLY ADJUST THE OPEN AND CLOSE CAMS.
  - 5) THE "FAIL" CONDITION IS SET PER THE SLIDE SWITCH ON THE SNS BOARD FOR FAIL OPEN OR FAIL CLOSE. USER IS TO SET THE "FAIL" POSITION SWITCH PRIOR TO APPLYING POWER TO THE UNIT.
  - 6) WHEN INCOMING POWER IS PRESENT, BLUE LED WILL BE LIT AND ACTUATOR RUNS OFF OF INCOMING POWER. WHEN INCOMING POWER FAILS, BLUE LED WILL TURN OFF AND THE YELLOW BATTERY LED WILL LIGHT - ACTUATOR WILL MOVE TO THE "FAIL" POSITION 1 TIME AND STAY THERE UNTIL POWER IS RESTORED.
  - 7) RED LED WILL LIGHT WHEN BATTERY VOLTAGE GETS TOO LOW. GREEN LED WILL LIGHT WHEN BATTERY VOLTAGE IS ABOVE 10.5VDC.
  - 8) DRY CONTACTS ARE PROVIDED TO INDICATE BATTERY STATUS AND INCOMING POWER STATUS. BATTERY STATUS CAN BE CHECKED WITH THE INCOMING POWER ON BY SHORTING THE 2 BATT TEST POINTS J7-2 & J10-1 MOMENTARILY.
  - 9) WHEN 24V MAINS POWER IS APPLIED TO THE ACTUATOR, THE MOTOR WILL DRIVE TO THE "CLOSE" POSITION. TO DRIVE THE ACTUATOR TO THE "OPEN" POSITION, APPLY +24VDC AND GND TO TERMINALS #4 & #6 AS SHOWN. WHEN THIS +24VDC SIGNAL VOLTAGE IS REMOVED, THE ACTUATOR WILL DRIVE BACK TO THE "CLOSE" POSITION.
  - 10) WHEN EITHER THE INCOMING POWER OR THE CONTROL SIGNAL FAILS, THE ACTUATOR WILL DRIVE TO THE CLOSE POSITION, IF THE FAIL SWITCH IS SET FOR "CLOSE".

W240322

**24VAC/VDC SNS2000 TWO WIRE OPEN/CLOSE WIRING DIAGRAM**

**CUSTOMER ELECTRICAL CONNECTIONS FOR MODULATING OPTION:**

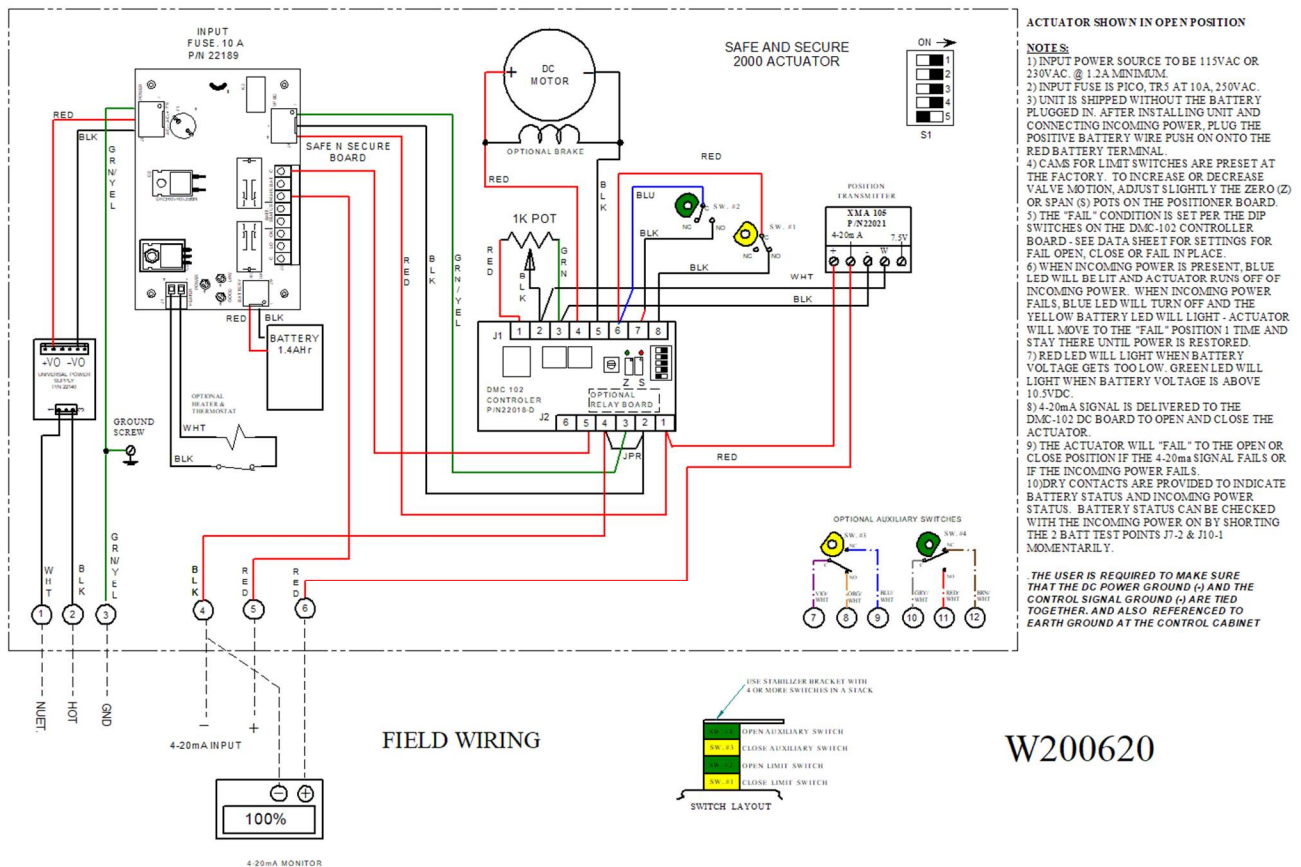

**115VAC/230VAC SNS2000 MODULATING W/TRANSMITTER WIRING DIAGRAM**

CUSTOMER ELECTRICAL CONNECTIONS FOR MODULATING OPTION:

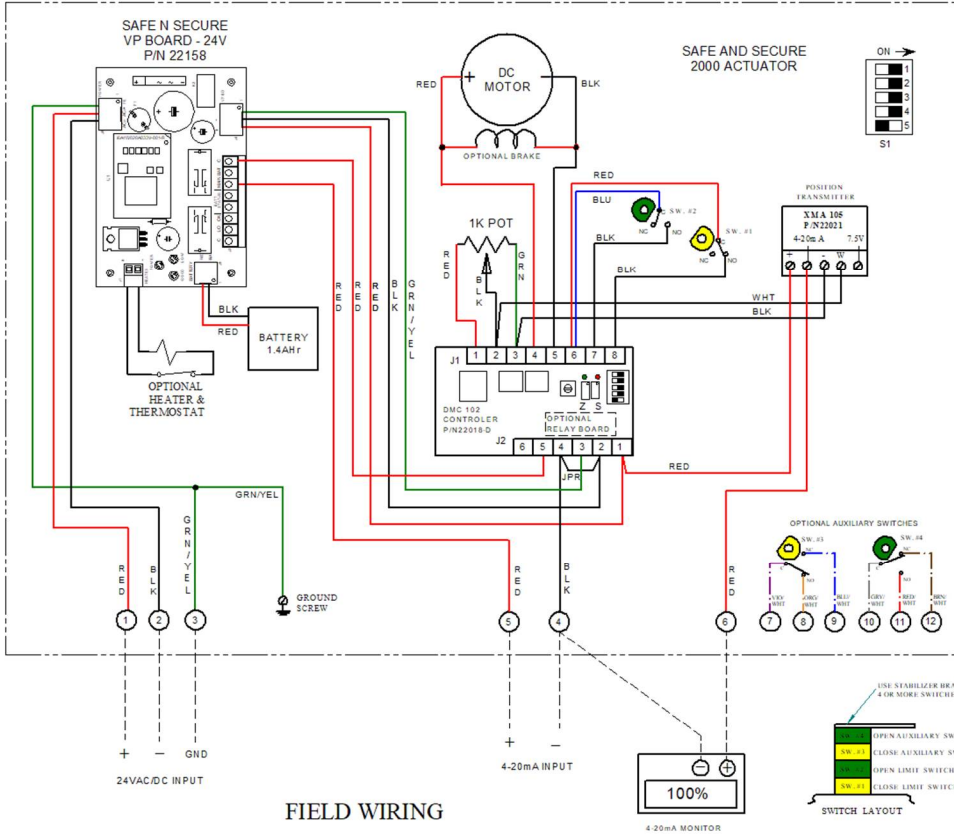

ACTUATOR SHOWN IN OPEN POSITION

- NOTES:**
- 1) INPUT POWER SOURCE TO BE 24VAC OR 24VDC @ 8A MINIMUM.
  - 2) INPUT FUSE IS PICO, TRS AT 10A, 250V AC.
  - 3) UNIT IS SHIPPED WITHOUT THE BATTERY PLUGGED IN. AFTER INSTALLING UNIT AND CONNECTING INCOMING POWER, PLUG THE POSITIVE BATTERY WIRE PUSH ON ONTO THE RED BATTERY TERMINAL.
  - 4) GMS FOR LIMIT SWITCHES ARE PRESET AT THE FACTORY. TO INCREASE OR DECREASE VALVE MOTION, ADJUST SLIGHTLY THE ZERO (Z) OR SPAN (S) POTS ON THE POSITIONER BOARD.
  - 5) THE "FAIL" CONDITION IS SET PER THE DIP SWITCHES ON THE DMC-102 CONTROLLER BOARD - SEE DATA SHEET FOR SETTINGS FOR FAIL OPEN, CLOSE OR FAIL IN PLACE.
  - 6) WHEN INCOMING POWER IS PRESENT, BLUE LED WILL BE LIT AND ACTUATOR RUNS OFF OF INCOMING POWER. WHEN INCOMING POWER FAILS, BLUE LED WILL TURN OFF AND THE YELLOW BATTERY LED WILL LIGHT - ACTUATOR WILL MOVE TO THE "FAIL" POSITION 1 TIME AND STAY THERE UNTIL POWER IS RESTORED.
  - 7) RED LED WILL LIGHT WHEN BATTERY VOLTAGE GETS TOO LOW. GREEN LED WILL LIGHT WHEN BATTERY VOLTAGE IS ABOVE 10.5VDC.
  - 8) 4-20mA SIGNAL IS DELIVERED TO THE DMC-102 DC BOARD TO OPEN AND CLOSE THE ACTUATOR.
  - 9) THE ACTUATOR WILL "FAIL" TO THE OPEN OR CLOSE POSITION IF THE 4-20mA SIGNAL OR IF INCOMING POWER FAILS.
  - 10) DRY CONTACTS ARE PROVIDED TO INDICATE BATTERY STATUS AND INCOMING POWER STATUS. BATTERY STATUS CAN BE CHECKED WITH THE INCOMING POWER ON BY SHORTING THE 2 BATT TEST POINTS J7-2 & J10-1 MOMENTARILY.

THE USER IS REQUIRED TO MAKE SURE THAT THE DC POWER GROUND (+) AND THE CONTROL SIGNAL GROUND (-) ARE TIED TOGETHER, AND ALSO REFERENCED TO EARTH GROUND AT THE CONTROL CABINET

W200629

24VAC/DC SNS2000 MODULATING W/TRANSMITTER WIRING DIAGRAM

**CUSTOMER ELECTRICAL CONNECTIONS FOR MODULATING OPTION:**

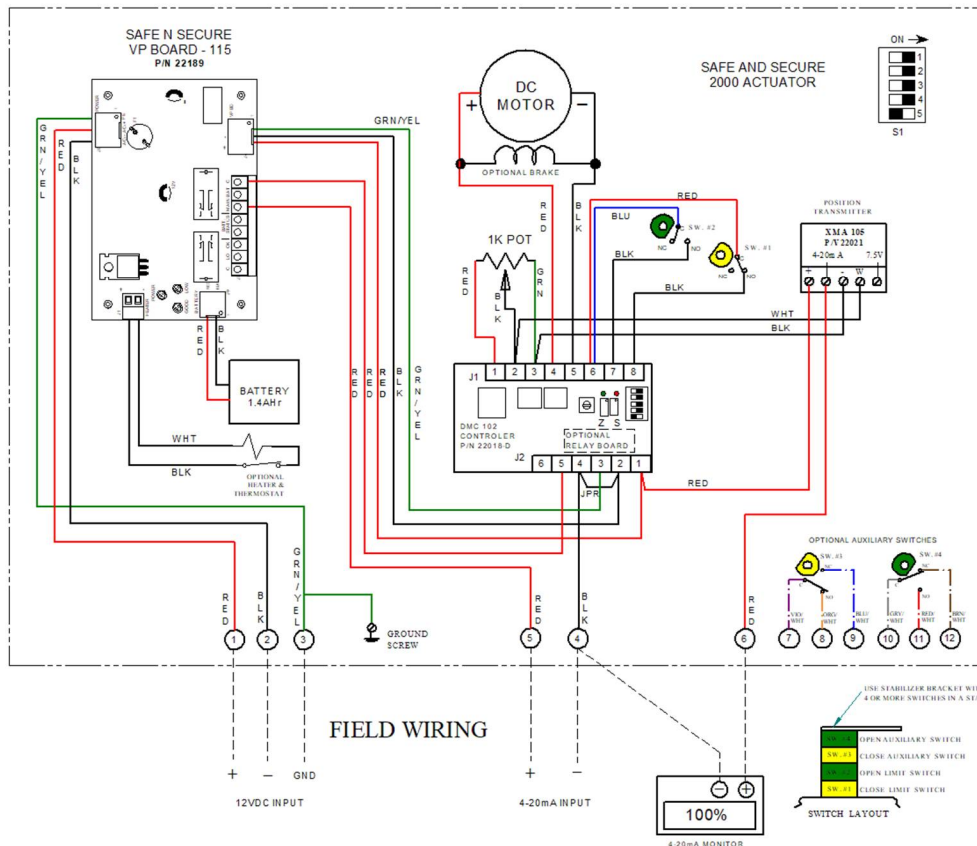

**ACTUATOR SHOWN IN OPEN POSITION**

**NOTES:**

- 1) INPUT POWER SOURCE TO BE 12VDC @ 10A MINIMUM.
- 2) INPUT FUSE IS PICO TR5 AT 10A, 250VAC.
- 3) UNIT IS SHIPPED WITHOUT THE BATTERY PLUGGED IN. AFTER INSTALLING UNIT AND CONNECTING INCOMING POWER, PLUG THE POSITIVE BATTERY WIRE PUSH ON ONTO THE RED BATTERY TERMINAL.
- 4) CAMS FOR LIMIT SWITCHES ARE PRESET AT THE FACTORY. TO INCREASE OR DECREASE VALVE MOTION, ADJUST SLIGHTLY THE ZERO (Z) OR SPAN (S) POTS ON THE POSITIONER BOARD.
- 5) THE 'FAIL' CONDITION IS SET PER THE DIP SWITCHES ON THE DMC-102 CONTROLLER BOARD - SEE DATA SHEET FOR SETTINGS FOR FAIL OPEN, CLOSE OR FAIL IN PLACE.
- 6) WHEN INCOMING POWER IS PRESENT, BLUE LED WILL BE LIT AND ACTUATOR RUNS OFF OF INCOMING POWER. WHEN INCOMING POWER FAILS, BLUE LED WILL TURN OFF AND THE YELLOW BATTERY LED WILL LIGHT - ACTUATOR WILL MOVE TO THE 'FAIL' POSITION 1 TIME AND STAY THERE UNTIL POWER IS RESTORED.
- 7) RED LED WILL LIGHT WHEN BATTERY VOLTAGE GETS TOO LOW. GREEN LED WILL LIGHT WHEN BATTERY VOLTAGE IS ABOVE 10.5VDC.
- 8) 4-20mA SIGNAL IS DELIVERED TO THE DMC-102 DC BOARD TO OPEN AND CLOSE THE ACTUATOR.
- 9) THE ACTUATOR WILL FAIL TO THE OPEN OR CLOSED POSITION IF THE 4/20 mA SIGNAL FAILS OR IF THE INCOMING POWER FAILS.
- 10) DRY CONTACTS ARE PROVIDED TO INDICATE BATTERY STATUS AND INCOMING POWER STATUS. BATTERY STATUS CAN BE CHECKED WITH THE INCOMING POWER ON BY SHORTING THE 2 BATT TEST POINTS J7-2 & J10-1 MOMENTARILY.

**THE USER IS REQUIRED TO MAKE SURE THAT THE DC POWER GROUND (-) AND THE CONTROL SIGNAL GROUND (-) ARE TIED TOGETHER, AND ALSO REFERENCED TO EARTH GROUND AT THE CONTROL CABINET**

W200630

**12VDC SNS2000 MODULATING W/TRANSMITTER WIRING DIAGRAM**

## ACTUATOR SET-UP FOR STANDARD & TWO WIRE ACTUATORS:

After the actuator is mounted mechanically to the valve and the external electrical wiring is complete, the actuator is ready for set up. The actuator cover will need to be removed, if not already done so.

- 1) On the circuit board, move the “**Fail Switch**” to the desired “**FAIL**” position. The description of the 2 positions are as follows:

**OPEN (UP)** = MOVES TO THE OPEN POSITION WHEN POWER FAILS.

**CLOSE (DOWN)** = MOVES TO THE CLOSE POSITION WHEN POWER FAILS.

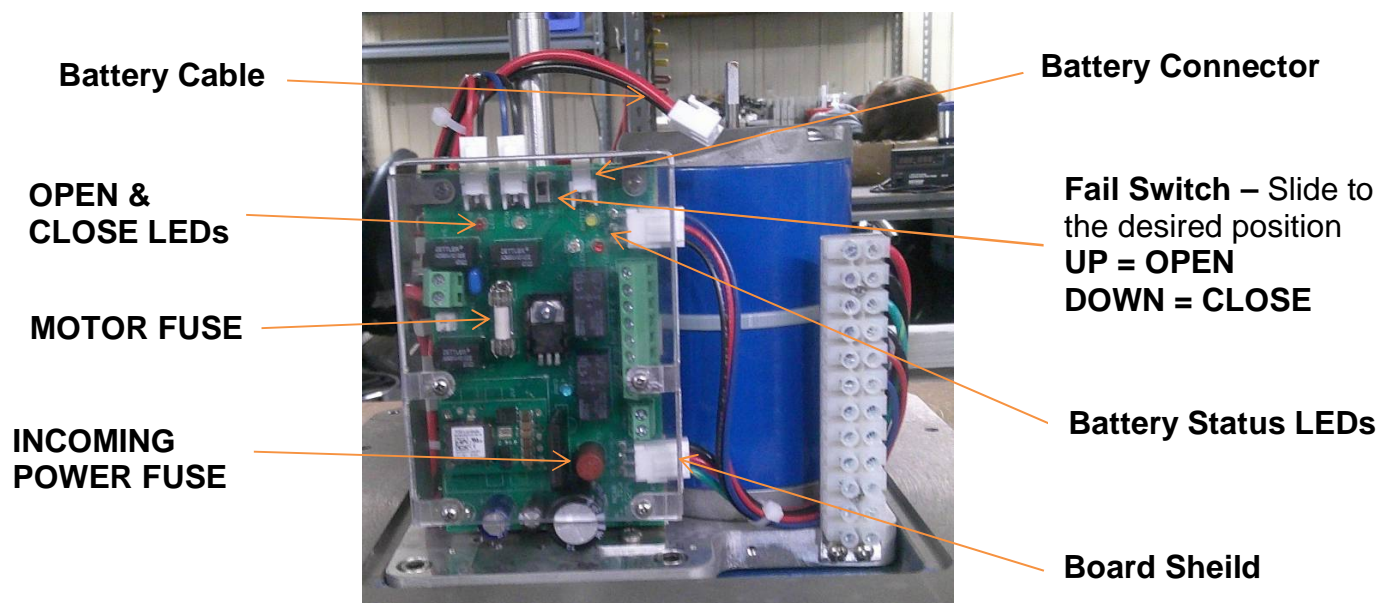

**WARNING: DO NOT switch the FAIL switch while the actuator is moving or while the battery is plugged into the SNS board. Turn OFF power & unplug the Battery Connector before moving the switch!**

- 2) Plug the battery connector into the 2 pin BATTERY header on the SNS Board.

**NOTE:** *If the “Fail Switch” was moved to the “CLOSE” position, the actuator will begin to move to CLOSE since the actuator is shipped in the OPEN Position.*

**Battery Connector –**  
Plug the battery connector into the 2 pin BATTERY header on the board.

**Main Power LED - Blue**

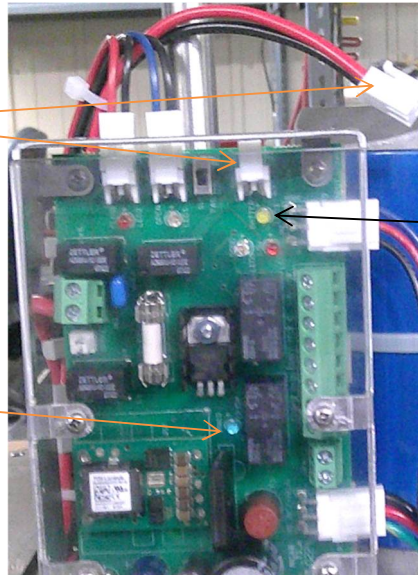

**Battery Power LED - Yellow**

- 3) Turn the Main external power to the actuator ON.
- 4) When the Main power is applied to the actuator, the Power LED (Blue) should illuminate. This will indicate that the Main Power is ON and the input fuse is good.
- 5) Apply the external direction control signal by connecting terminal #4 to #5 to CLOSE and to terminal #4 to #6 to OPEN. Only apply the signal to OPEN or CLOSE individually and NOT at the same time. **Applying the control to the OPEN and CLOSE at the same time will damage the circuit board and the motor.** Also, do not apply an external voltage to the OPEN or CLOSE control signal pins – this will damage the circuitry. The +12vdc voltage on terminal #4 should be the only voltage applied to terminals #5 or #6 for controlling the actuator.
- 6) Using the external direction control signal, run the actuator OPEN and CLOSE to verify that the valve is opening and closing fully. If not, the Open and Close CAMs may be adjusted to allow more or less motion in both directions. Rotate the CAM Clockwise for less rotation (shorten the valve stroke); Counter Clock Wise for more rotation (increase the valve stroke – further into the seat). The CAM set screw needs to be loosened to rotate the CAM. Re-tighten the set screw when the desired valve position is achieved.



**Battery Mounting**

**Auxiliary Switches (if installed) top 2**

**Limit Switch CAMs**  
(Bottom = Close; Top = Open) – Loosen the set screw to rotate for adjustment.

**NOTE:** If control signal is provided by a PLC relay, program needs to incorporate a delay between the OPEN & CLOSE signal to prevent Back EMF damage to the PC Board.

The external control signal is done using a dry contact switch or relay. **DO NOT APPLY** an External voltage to the OPEN or CLOSED control signal pins. The voltage is provided on terminal #4 via the SNS control board.

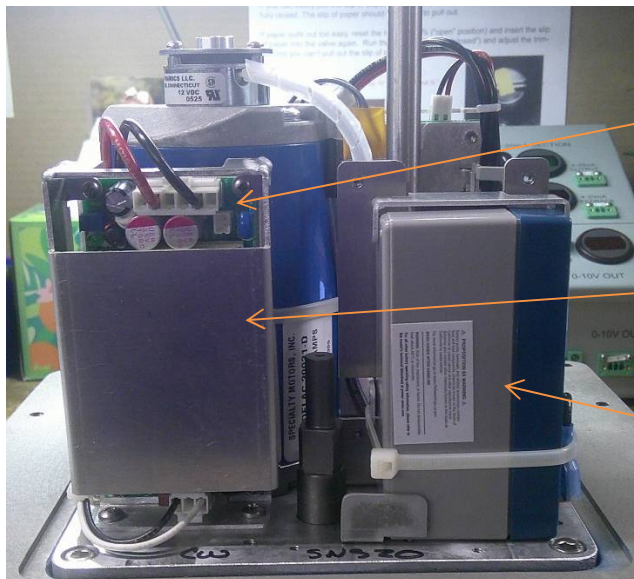

**115/230vac Power Supply** (only used on 115/230vac units)

**Power Supply Board Shield**

**Battery, 12vdc 1.4Ahr**

**Standard Actuator View of Power Supply**

- 7) If making any External Connections for Status Indication and Relay Outputs, power down the actuator and unplug the battery power connector from the Circuit Board.
- 8) See the *External Features & Connections Section* in this manual for connections, descriptions and operation of these features. All wiring must be done with ALL power OFF.
- 9) Once all External Connections are made and terminal screws are tight, re-connect the battery connector, J2, and turn the power to the actuator back ON. Re-install the Actuator Cover and tighten the Cover Bolts to the proper torque.

**NOTE:** When re-installing the actuator cover, pay close attention to the wiring and make sure that none of the wires get pinched or damaged.

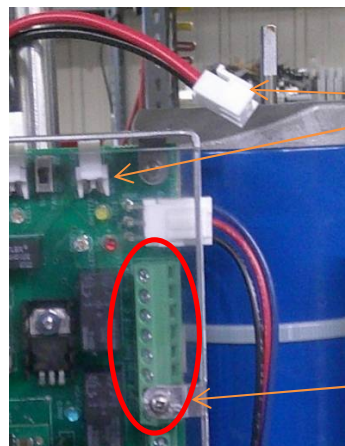

**Unplug Battery Connector before making External Connections**

**External Connections Terminal Block**

## TWO WIRE SIGNAL CONTROL

When using the Two Wire Signal Control on the SNS2000 Series, all of the above Set-Up Steps are the same EXCEPT for Signal Connections in Steps #5 & #6. See below:

If this Operation Option is ordered, a relay will be installed into the K6 slot on the board and the Standard Open/Close Operation will not work. **Refer to the Wiring Diagrams on Page 11.** The Actuator will drive to the CLOSE position when power is applied to the actuator. When +24vdc is applied to Terminals #4 & #6 the actuator will drive to the OPEN position. When that +24vdc signal is removed, the actuator will automatically drive BACK to the CLOSE position.

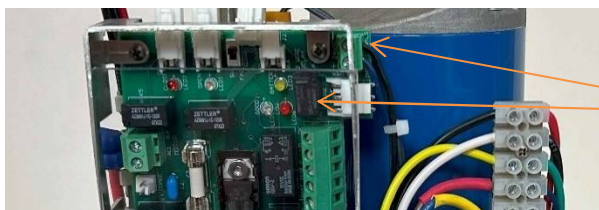

**Two Wire Signal Operation Option – K6 Installed** (wires connected to 2 pin Green Connector)

## ACTUATOR SET-UP FOR MODULATING OPTION ACTUATOR:

After the actuator is mounted mechanically to the valve and the external electrical wiring is complete, the actuator is ready for set up. The actuator cover will need to be removed, if not already done.

- 1) The Safe & Secure board will supply power to the Modulating Controller Board. When the incoming power to the unit fails, the battery will supply power to the Controller Board which will run the motor to the selected FAIL position that is set on the Positioner Board.

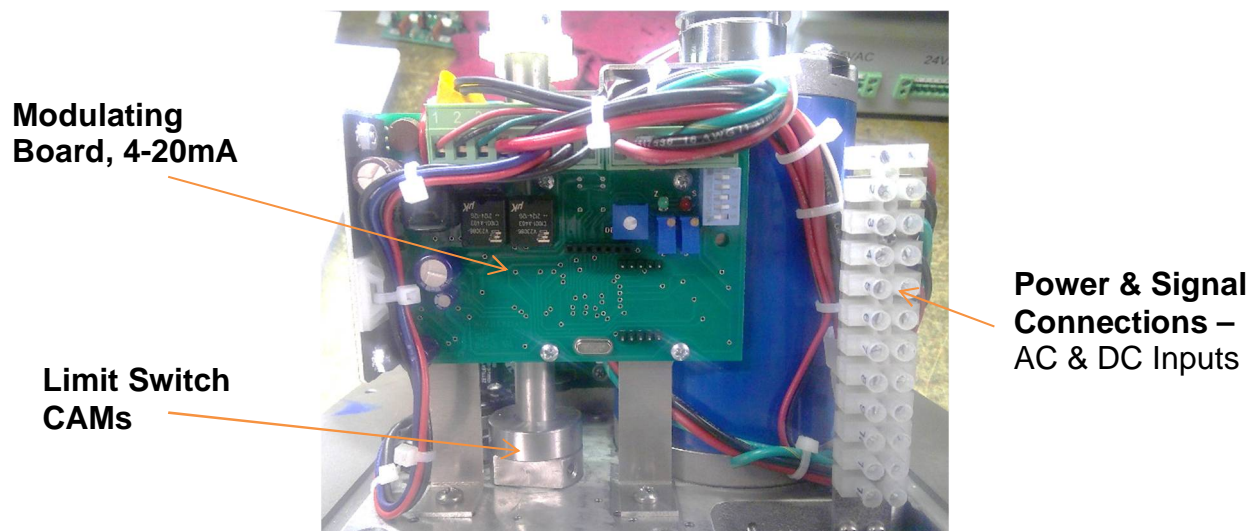

### DC Modulating Controller Board

- 2) Set the DIP Switch #3 to ON (right) & #4 to OFF (left) on the DMC 102 Controller Board. This will run the actuator to the CLOSED position in the event of a **loss of input control signal or Main Power**. If it is desired to have the actuator go to the OPEN position when this occurs, then DIP Switch #3 is set to OFF (left) & #4 is set to ON (right). Refer to the following Chart on the next Page.

**\*\*DO NOT CHANGE THESE SWITCH SETTINGS WITH THE POWER ON!!**

# S1

## COMMAND INPUT SIGNAL CONFIGURATION

| COMMAND TYPE | SW1 | SW2 | SW3 | SW4 | LOSS OF COMMAND OPERATION |
|--------------|-----|-----|-----|-----|---------------------------|
| 4-20mA       | ON  | ON  | ON  | ON  | Motor off                 |
|              |     |     | ON  | OFF | Close (Zero setting)      |
|              |     |     | OFF | ON  | Open (Span setting)       |
| 1-5V         | OFF | ON  | ON  | ON  | Motor off                 |
|              |     |     | ON  | OFF | Close (Zero setting)      |
|              |     |     | OFF | ON  | Open (Span setting)       |
| 2-10V        | OFF | OFF | ON  | ON  | Motor off                 |
|              |     |     | ON  | OFF | Close (Zero setting)      |
|              |     |     | OFF | ON  | Open (Span setting)       |
| 0-5V         | OFF | ON  | OFF | OFF | NA                        |
| 0-10V        | OFF | OFF | OFF | OFF | NA                        |

NOTE: All other settings are not valid and can cause abnormal operation.

| CONTROL FUNCTION | SW5 |
|------------------|-----|
| Calibrate/Normal | OFF |
| Log Rate         | ON  |



**Switch settings for Standard 4-20mA Input with FAIL In Place Option**

**Green & Red LEDs –**  
Close (Green) and Open (Red) indicators

**Deadband Pot**

**Zero Pot**

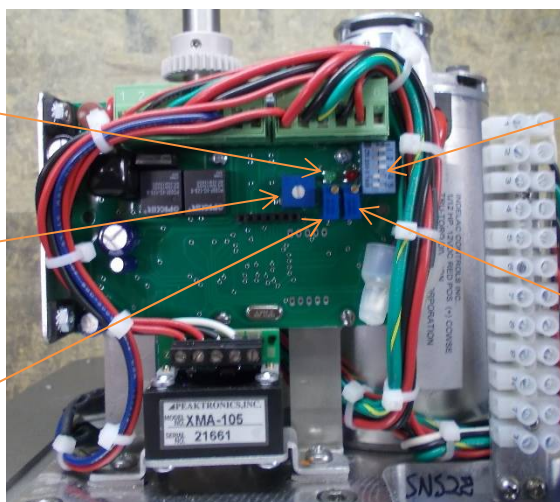

**Configuration Dip Switches**

**Span Pot**

- 3) If using the 0-10vdc or 1-5vdc Control Signal, the actuator will NOT fail to an OPEN or CLOSE position. The actuator will only **FAIL IN PLACE**. The FAIL OPEN or FAIL CLOSE will only work when using the 4-20mA Input Control Signal.
- 4) Plug the battery connector onto the 2 pin BATTERY Header on the SNS Board.

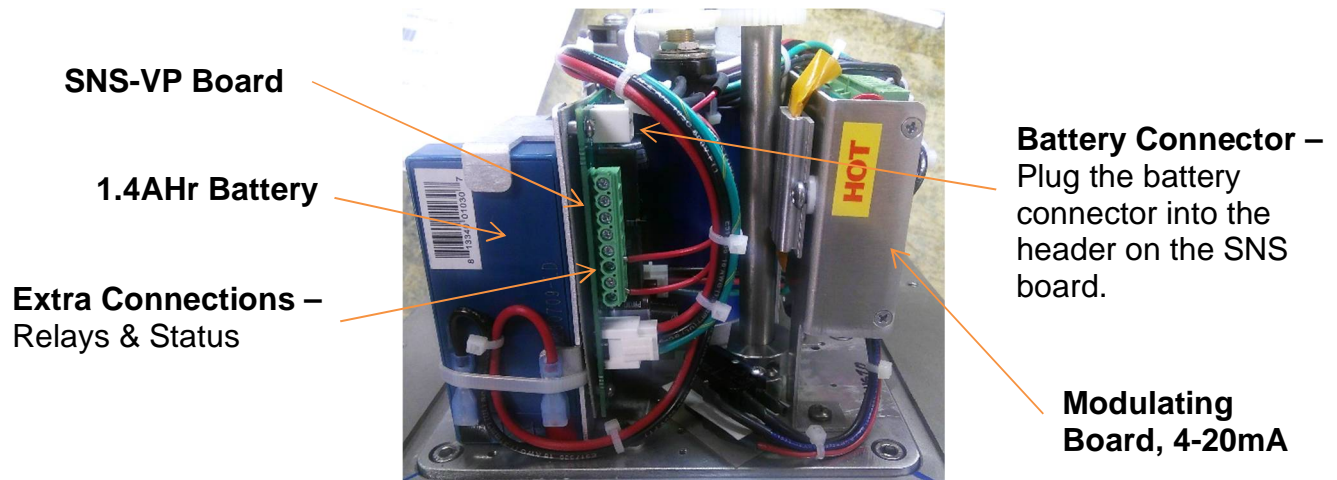

- 5) Turn on the Main external power to the actuator.
- 6) The Power LED (Blue) on the SNS-VP Board will turn on indicating Main Power is on and the input fuse is good.
- 7) Apply the input signal (4-20mA, 0-10v, etc.) to run the actuator open and closed to verify that the valve is opening and closing fully. If not, the ZERO and SPAN pots on the Modulating Controller Board may be adjusted to allow more or less motion in that particular direction.
- 8) If making any External Connections for Status Indication and Relay Outputs, power down the actuator and unplug the battery power connector from the Circuit Board.
- 9) See the *External Features & Connections Section* in this manual for connections, descriptions and operation of these features. All wiring must be done with ALL power OFF.
- 10) Once all External Connections are made and terminal screws are tight, re-connect the battery connector, J2, and turn the power to the actuator back ON.
- 11) Re-install the Actuator Cover and tighten the Cover Bolts to the proper torque.

**NOTE:** When re-installing the actuator cover, pay close attention to the wiring and make sure that none of the wires get pinched or damaged.

## STANDARD OPEN/CLOSE ACTUATOR OPERATION:

Upon applying external Mains Power to the actuator, the Blue LED on the Safe & Secure Board should illuminate indicating that the power from the external source is on and the input fuse is good. When the external power fails or the input fuse blows, the Blue LED will turn off and the Yellow Battery LED will illuminate indicating that the actuator is now running on battery power. When this occurs, the actuator will move to the desired FAIL position (OPEN or CLOSED), as selected by the operator during set-up.

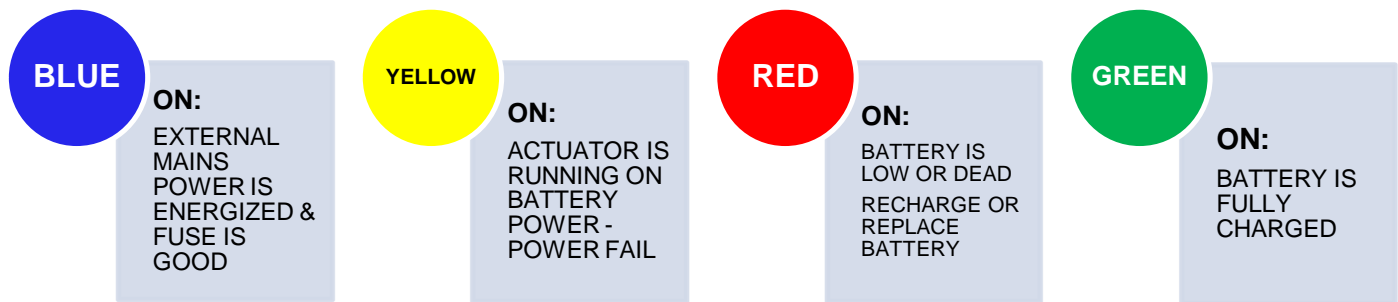

For example, if the actuator is moving towards the OPEN position with the Fail Switch on the SNS Board set for CLOSED, the actuator will STOP, and move to the CLOSE position if the external Mains Power or Input Power Fuse should fail.

**WARNING: DO NOT CHANGE THE FAIL SWITCH SETTING WITH THE POWER ON!! POWER OFF BEFORE CHANGING ANY SWITCH SETTINGS!**

When the incoming power fails, the battery status LED (Green or Red) will also illuminate to show the charge level of the battery. If the Green LED is on, the battery is at full power, but if the Red LED is illuminated, the battery power is low and will need to be charged. If neither the Green nor Red LED is lit under battery power, the battery is completely dead and will need to be replaced. In the instance of a dead battery, the Yellow LED will not be illuminated. **If the battery is too low, the actuator will FAIL in place.**

The Actuator operates when the internal +12vdc Signal Power (Terminal #4) is connected to the OPEN Terminal #5 or the CLOSE Terminal #6. **DO NOT** apply an **External Voltage** to the Control Signal Terminals – this will damage the PCB. Only one signal can be powered at a time – **DO NOT Connect Terminal #4 to Terminal #5 AND #6 at the same time!**

**NOTE:** If control signal is provided by a PLC relay, program needs to incorporate a delay between the OPEN & CLOSE signal.

The external control signal is delivered using a dry contact switch or relay. **DO NOT APPLY** an external voltage to the OPEN or CLOSED control signal pins. The voltage is provided by terminal #4 via the SNS control board.

The unit will indicate direction of operation (OPEN or CLOSE) by lighting the OPEN (Green) or CLOSE (Red) LED. If, for instance, an OPEN signal is delivered to the actuator, the OPEN Green LED should turn on and the actuator should move to the OPEN position. If that Green LED turns on and the motor does not move, then the Motor Fuse has blown or there is a problem with the PC Board. When the Full OPEN or Full CLOSE Position has been reached, the corresponding Limit Switch will trip to stop the Motor and the OPEN (Green) or CLOSE (Red) LED will Turn OFF.

There is a battery charge circuit built into the Safe & Secure actuator that will charge the battery when the external power is on. After a full 8-10 hour charge, the Green battery status LED will illuminate. If after 8-10 hours of “on board” charging, the Red LED remains on, then the battery needs to be replaced. IF the battery needs to be replaced, see the **BATTERY OPERATION, INSTALLATION & MAINTENANCE SECTION**. The battery charge circuit will complete the “boost” charge on the battery until it reaches a “Fully Charged” level then it will go into a “Trickle” charge mode. This will maintain the battery until it is needed again.

If the Optional Heater has been installed, the Heater will operate when the external power supply is on. **BE CAREFUL: The Heater will be HOT!** If the external power supply should fail and the actuator runs on battery power, the Heater will **NOT** be operational.

The Actuator Cover will need to be removed to Observe the Status LEDs as described in this **OPERATION** Section. Please see the photos in the previous pages of this manual for the locations of the above mentioned boards and LED locations. Whenever the Actuator Cover is being re-installed, pay close attention so that the wires and components do not get pinched or damaged.

## TWO WIRE CONTROL ACTUATOR OPERATION:

The Board used for the Two Wire Control Signal Option is basically the same as the above Standard Open/Close Operation. All of the connections and features are the same EXCEPT for the control signal connection and it's operation. The LEDs, battery operation and charging are all the same.

If this Operation Option is ordered, a relay will be installed into the K6 slot on the board and the Standard Open/Close Operation will not work. Refer to the Wiring Diagrams on Page 11. The Actuator will drive to the CLOSE position when power is applied to the actuator. When +24vdc is applied to Terminals #4 & #6 the actuator will drive to the OPEN position. When that +24vdc signal is removed, the actuator will automatically drive BACK to the CLOSE position without being commanded.

Typically, the actuator board is set for FAIL CLOSE so that the actuator will drive to the standby CLOSE position when the power fails. The CLOSE position is also the standby position the actuator will drive to when power is applied.

## MODULATING ACTUATOR OPERATION:

Modulating Actuators allow the User to *precisely* position the actuator/valve to control flows and processes using an adjustable input signal. Upon applying external Mains Power to the actuator, the Blue LED on the Safe & Secure Board should illuminate indicating that the power from the external source is on and the input fuse is good. When the incoming power fails, the Blue LED on the SNS Board will turn OFF and one of the Battery Status LEDs will turn ON (Green or Red). There is no Yellow Battery LED on the Modulating SNS Board.

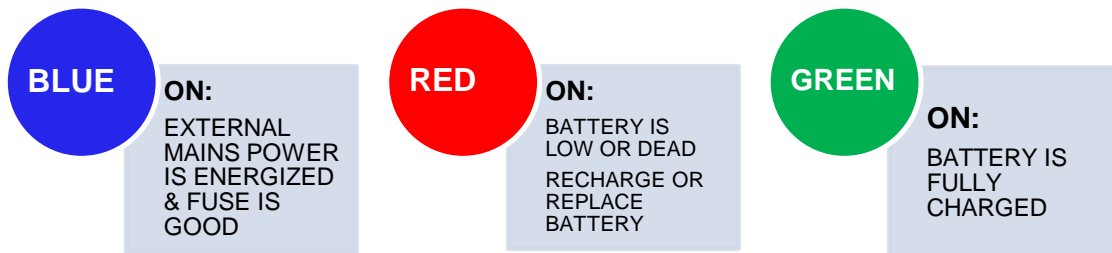

On the Modulating version, the FAIL position is set by the DIP Switches on the Modulating Control Board as described in the **SET UP FOR MODULATING ACTUATORS** Section. When the Mains Power FAILS, the Battery Power will drive the actuator to the User Selected Fail Position and remain there until the Mains Power comes back ON. Also, if the Control Signal wires should become damaged or dis-connected, the Actuator will drive to the Fail Position until that is repaired.

**WARNING: DO NOT CHANGE THE DIP SWITCH SETTING WITH THE POWER ON!!  
POWER OFF BEFORE CHANGING ANY SWITCH SETTINGS!**

The Modulating version actuator is controlled by an external 4-20mA, 0-10vdc or 1-5vdc Control Signal. Indelac actuators are calibrated and adjusted to accept a 4mA signal for full CLOSE and a 20mA signal for full OPEN at the factory. Changes to the type of signal and Reverse Acting can be ordered Special or Set Up in the field using the Instructions in the 22108-D Manual. Any changes will require re-calibration of the Modulating Board. Remember: if the 0-10vdc or 1-5vdc Control Signal Option is selected, the Actuator will **ONLY FAIL IN PLACE** and not to the OPEN or CLOSE positions.

The Actuator will indicate OPEN and CLOSE motion by lighting the Red (OPEN) and Green (CLOSE) LEDs on the Modulating Control Board, 22018-D. The Actuator will precisely move the valve to the desired position as commanded by the Control Signal. When a 4mA Control Signal is delivered to the Actuator, the Green LED should turn ON and the actuator should move to the CLOSE position. Likewise, if a 20mA signal is delivered, the Red LED should turn ON and the Actuator should move to the OPEN position. If the Red or Green LED is ON and the actuator is not moving when a control signal is delivered, check the Calibration of the Actuator and OPEN/CLOSE CAMs for proper adjustments. The Actuator may need to be Re-calibrated if there is no movement when a Control Signal is delivered. See the **MODULATING BOARD CALIBRATION PROCEDURE** Section.

There is a battery charge circuit built into the Safe & Secure actuator that will charge the battery when the external power is ON. After a full 8-10 hour full charge, the Green battery status LED will illuminate. If after 8-10 hours of “on board” charging, the Red LED remains on, then the battery needs to be replaced. **If the battery is too low, the actuator will FAIL in place.**

If the Optional Heater has been installed, the Heater will operate when the external power supply is on. **BE CAREFUL: The Heater will be HOT!** If the external power supply should fail and the actuator runs on battery power, the Heater will **NOT** be operational.

The Actuator Cover will need to be removed to Observe the Status LEDs as described in this **OPERATION** Section. Please see the photos in the previous pages of this manual for the locations of the above mentioned boards and LED locations. Whenever the Actuator Cover is being re-installed, pay close attention so that the wires and components do not get pinched or damaged.

**MODULATING BOARD CALIBRATION PROCEDURE:**

If the Modulating Actuator should not respond to the input signal properly, the unit may need to be recalibrated back to the factory settings. Follow the below steps to re-calibrate the unit.

- 1) Power and run the motor and valve to 45° or mid-position between open and close. If the actuator will not run, you may need to manually over ride the position using the declutching manual over ride hand wheel.
- 2) Turn the Mains power to the actuator OFF so that the motor does not move.
- 3) Loosen set screw on the potentiometer shaft gear.

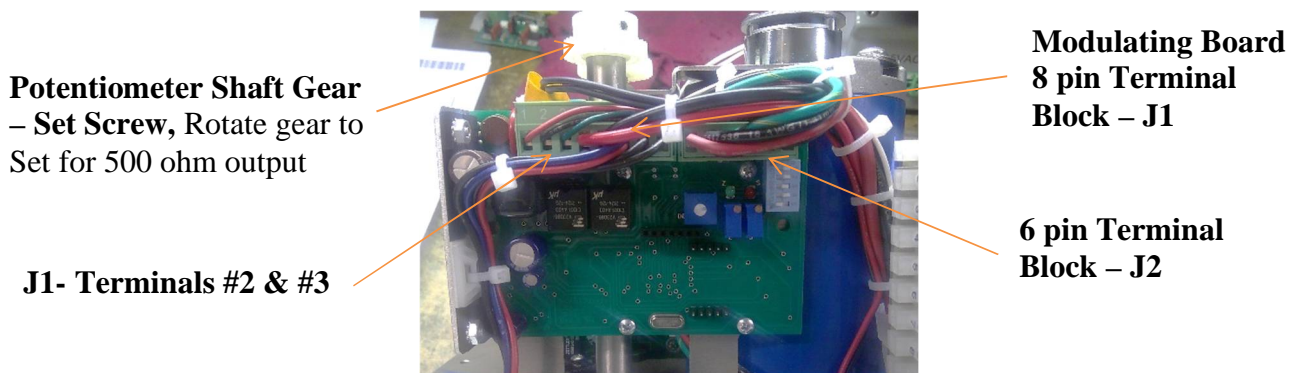

- 4) Pull the 8-terminal J1 green connector out away from the controller board so that the potentiometer is isolated from the circuit card.
- 5) Using a Digital Volt Meter (DVM), measure the resistance of the potentiometer between terminals 2 & 3 at the free hanging J1 connector.
- 6) Rotate the potentiometer shaft gear until the resistance reads approximately 500 ohms (+/-10).

- 7) Tighten down the potentiometer shaft gear set screw to lock the gear in place.
- 8) Push the green J1 connector back into the controller board.
- 9) Connect a User Control Signal (4-20mA, 0-10v, etc.) to the actuator input terminals. Consult your actuator's wiring diagram for the proper terminal connections.
- 10) Set the User Control Signal to the CLOSE level (0%) - 4.0mA or 0V.
- 11) Make sure the Deadband pot on the controller board is adjusted to its mid position.
- 12) Turn the Mains power back ON to the actuator. Use **CAUTION** with the next few steps because power is present and an electrical shock is possible.
- 13) The Green LED on the board should come on. If not, adjust the Zero Pot in small increments until the Green LED illuminates.

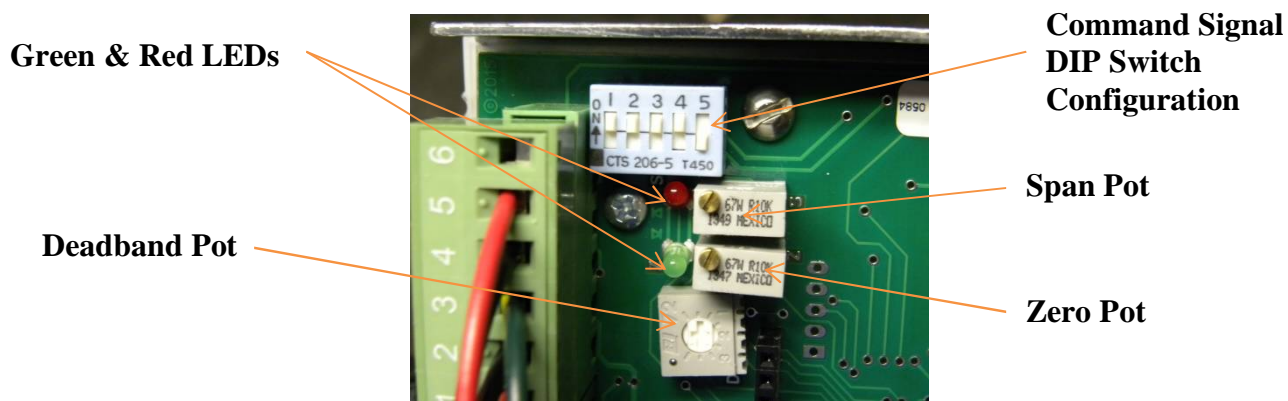

- 14) If any of the LEDs are blinking or flashing or there is a question regarding the setup of the Command Signal, please see **SET UP FOR MODULATING ACTUATORS** Section.
- 15) Keep adjusting the Zero Pot in small increments until travel to the full Valve CLOSED position is reached. This may require moving the pot both Clockwise and Counter-Clockwise to get to the proper valve position.
- 16) Adjust the Zero Pot so that both the Green and Red LEDs are OFF.
- 17) If at any time during the adjustments, the GREEN LED is on but the motor will not move in the CLOSE direction, the CAM for CLOSE may need to be adjusted. When moving to the full CLOSE position, the CLOSE CAM switch lever must be pressed in to allow the motor to move. If it is not, loosen the bottom CLOSE CAM set screw and rotate that CAM so that the switch lever is pressed in.

**Open CAM, top**

**Close CAM, bottom**

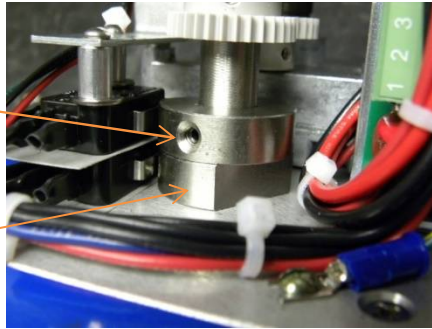

- 18) Set the User Control Signal to the OEPN level (100%) - 20.0mA or 10V.
- 19) The Red LED should turn on.
- 20) Verify that the valve moves in the OPEN direction.
- 21) If the valve does not reach the fully OPEN position, adjust the Span pot in small increments to get the valve to the full OPEN position.
- 22) Adjust the Span Pot so that both the Green and Red LEDs are OFF.
- 23) If at any time during the adjustments, the RED LED is on but the motor will not move in the OPEN direction, the CAM for OPEN may need to be adjusted. When moving to the full OPEN position, the OPEN CAM switch lever must be pressed in to allow the motor to move. If it is not, loosen the 2<sup>nd</sup> up OPEN CAM set screw and rotate that CAM so that the switch lever is pressed in.

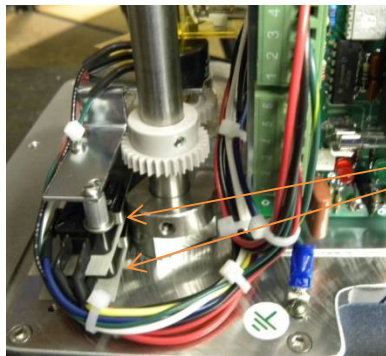

**Limit Switch  
Levers Pressed In  
to Switch Body**

- 24) Deliver OPEN, MID and CLOSE (0%, 50% & 100%) Control Signals a few times to verify that the valve travels to the proper positions. If further adjustments are needed, re-adjust the pots as described in the above steps.
- 25) Turn OFF the Mains Power and check that all of the set screws, wire terminal screws and terminal blocks are tightened. Carefully replace the actuator cover and tighten the screws. Take care not to pinch or damage any wires with the cover.
- 26) Re-apply the Mains power to the actuator and re-check all of the settings.

**NOTE:** When re-installing the actuator cover, pay close attention to the wiring and make sure that none of the wires get pinched or damaged.

**EXTERNAL FEATURES & CONNECTIONS:**

There are a few features available on the SNS2000 Series Actuator that will allow for external monitoring of the actuator status. By connecting wires to the External Connections Terminal Block on the SNS PCB, the user can monitor the status of the Incoming Power vs. Battery Power and the Charge Level of the Battery from their Remote Control Panel.

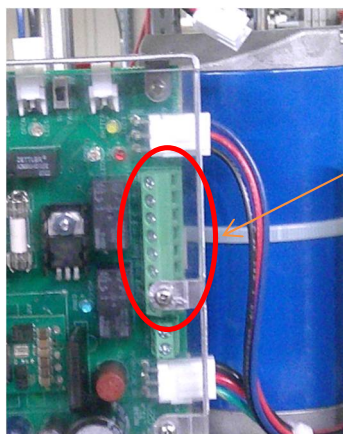

**Standard Open/Close SNS Board**

**External Connections Terminal Block**

**NOTE:** Verify that ALL Power is OFF to the Actuator prior to connecting any External Connection wiring for the relay features or Test Switches.



**Modulating SNS Board**

**INCOMING POWER STATUS:**

The SNS2000 boards have an on-board relay that will output the status of the incoming power. When the Incoming Mains Power is powering the actuator, the Blue LED will be ON and there will be continuity between Terminals 1 & 3 on the External Connections Terminal Block. When the incoming Mains Power fails and the unit switches over to Battery Power, the connection between Terminals 1 & 3 will OPEN and there will be continuity between Terminals 2 & 3, indicating that the unit is running on Battery Power.

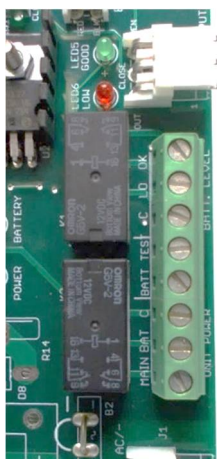

- 3 – Common**
- 2 – Battery**
- 1 – Mains Power**

| Power Status         | Terminals<br>1 to 3 | Terminals<br>2 to 3 |
|----------------------|---------------------|---------------------|
| <b>Mains Power</b>   | Continuity          | OPEN                |
| <b>Battery Power</b> | OPEN                | Continuity          |

**External Connections Terminal Block, SNS2000 PCB**

### BATTERY CHARGE LEVEL:

There is also an on-board relay that will output the status of the battery charge. When the SNS2000 is running on Battery Power, the Yellow LED will be ON. If the battery has a FULL Charge, there will be continuity between Terminals 6 & 8 on the External Connections Terminal Block and the Green Battery LED on the PCB will be ON. If the battery voltage drops below 9 volts DC, the connection between Terminals 6 & 8 will OPEN and there will be continuity between Terminals 6 & 7, indicating that the battery is too LOW to adequately run the actuator. The Red Battery LED will also be illuminated.

If the battery charge drops below 2-4vdc, neither of the Battery LEDs will illuminate and the Battery Charge Relay will be in the “LOW” charge position with continuity between Terminals 6 & 7.

**Battery Status LEDs**

- 8 – Battery OK**
- 7 – Battery Low**
- 6 – Common**
- 5 – Test #1**
- 4 – Test #2**

**N.O. Test Switch**

|                       |                  |                  |
|-----------------------|------------------|------------------|
| Battery Charge Status | Terminals 6 to 7 | Terminals 6 to 8 |
| <b>Battery Low</b>    | Continuity       | OPEN             |
| <b>Battery Good</b>   | OPEN             | Continuity       |

**External Connections Terminal Block, SNS2000 PCB**

### Battery Charge Status Test with Mains Power ON or Actuator Running:

The SNS2000 board also has a feature to test the Battery Charge Status when the Mains Power is ON. By connecting a **Normally Open Test Switch** between Terminals 4 & 5 (shown above), the user will be able to remotely check the Battery Charge Status during Normal Operation. When the Normally Open Switch is Closed (continuity between Test #1 & #2), the Battery Charge Circuit is disconnected from the battery, and the TRUE condition of the battery is displayed through the Battery Charge Level Relay and the Battery Status LEDs.

In this “Test” Mode with the N.O. Test Switch CLOSED, the User will be able to determine the Battery Charge Level by reading the same conditions as listed above. When the N.O. Test Switch is OPENED back up, the Battery Charge Circuit is re-connected to the Battery to resume charging and the Battery Status LEDs will turn OFF.

**BATTERY OPERATION, INSTALLATION & MAINTENANCE:**

The battery (#32016) in the SNS2000 is a Sealed Lead Acid, 12vdc, 1.4AHr Rechargeable Unit. The SNS2000 is shipped with the battery connector disconnected, so there is no load on the battery. The actuator can be stored for 4-6 months in this “no load” condition before the battery will need to be recharged. If these actuators are stored longer than this before being installed, the customer needs to implement a program to charge these batteries for 8-10 hours every 4 months. This will maintain the batteries until installation. If these batteries are NOT maintained, they will be too low or dead and not operate when needed.

**\*\*\* Field Installation of the battery is ONLY permitted when the area is non-hazardous or known to be free of an ignitable concentration of hazardous materials.**

**Loosen Battery Retention Bracket Screw & Rotate Bracket to Slide Battery Out.**



**Unplug Battery Wires from Terminals, 2 Places**

**Battery Removal & Replacement**

The battery life is typically 4 years as long as kept on a maintenance/trickle charge. If the actuator is installed and the battery connector is plugged into the SNS PCB, J2, the Mains Power needs to be turned ON to the actuator to maintain the battery. The “on-board” trickle charger will maintain the battery for use when needed. If the Main Power is shut OFF or the Main Power Fuse blows, the actuator will be operating under battery power and illuminates the PCB LEDs. This will drain the battery over a shorter amount of time, and the Main Power needs to be repaired to power the actuator.

**ATTENTION:** The battery condition and charge level should be checked after installation of the unit and before putting the Actuator into service. Use an Electrical Meter to check the battery voltage AND with No Mains Power applied, verify that the Green Battery Status LED is illuminated.

Once the battery charge gets below 6-7vdc, it may not take a charge due to internal cell damage. To charge a battery that low, the “on board” trickle charger will not work. A larger charger, such as the Indelac #33001, will re-charge low batteries. Even if it does take a charge, the battery may be unreliable and **SHOULD be REPLACED!**

**NOTE:** Care should be used whenever using a battery source for power. Sealed Lead Acid (SLA) batteries are designed to be mounted in any position without leaking. Take great care NOT to pinch or crush the battery wires with the Actuator Cover or brackets as this may cause damage and/or arcing and short out the battery.

## MOTOR OVER LOAD:

The Safe and Secure series actuator motors are internally fused with a 250v, 10A, 5x20mm glass cartridge slow blow fuse (#46039). When the motor current rises to an overload level, the on-board fuse will blow and will need to be replaced. The fuse must be replaced with an equivalent fuse to keep from damaging the system. It is the responsibility of the operator to check the entire system and clear any jams or valve binding prior to replacing the fuse and restarting the system.

## MECHANICAL OVER LOAD:

Indelac actuators are all designed to withstand stall conditions. It is not recommended to subject the unit to repeated stall conditions.

## SPARE PARTS:

The SNS 2000 Actuators require very little maintenance. If a failure should occur, a list of field replaceable parts is shown in the chart below. When calling for spare parts, please include your Model Number, Serial Number, Description and Date of Installation.



**10A Motor Fuse  
5x20mm**



**10A Incoming Power Fuse  
TR5**

If the unit is not working and it is suspected that there is a failure in the Positioner Board, the SNS2000 Actuator will need to be sent back to Indelac for repair and re-calibration.

| Spare Part                            | Indelac Part Number |
|---------------------------------------|---------------------|
| CLOSE Switch with wires               | 24000-VC            |
| OPEN Switch with wires                | 24000-VO            |
| Battery, 1.4Ahr                       | 32016               |
| Fuse, 10A, 250V, TR5 – Incoming Power | 46045               |
| Fuse, 10A, 250V, 5x20mm – Motor       | 46039               |
| SNS2000 PCB, Standard, 12v, 115/230   | 22165               |
| SNS2000 PCB, Standard, 24v AC & DC    | 22152-A             |
| SNS2000 PCB, VP Ver., 12v, 115/230    | 22189               |
| SNS2000 PCB, VP Ver., 24v AC & DC     | 22158               |
| #25020 Heater Kit, with screws        | 90030               |
| #45014 12vdc Power Off Brake Kit      | 90031               |
| SNS Auxiliary Switch Kit, 2 Switches  | 90100-2             |

## OPTIONAL AUXILIARY SWITCH OPERATION AND INSTALL:

*The Optional Snap Action Auxiliary Switches are SPDT and the contacts are rated for:*

**10 Amps @ 250 VAC.**

Auxiliary Switches are wired so that the switch “opens” when the actuator reaches the desired position and there is continuity between the Common and N.C. contacts of the switch. For example, when the actuator reaches the full OPEN position, the OPEN Auxiliary Switch will open and complete the circuit (continuity) between Common & N.C. This works the same for the CLOSE Auxiliary Switch in the CLOSE position. The CAMs for these switches can be adjusted to trigger a signal per the user requirements. Or, the Common and N.O. contacts can be used for the reverse effect.

Auxiliary switches (maximum 2 per actuator), can be set to any desired position throughout the travel of the actuator rotation. This is done by loosening the Auxiliary Switch CAM set screw and rotating the CAM to the desired position. When the position is set, re-tighten the CAM set screw.

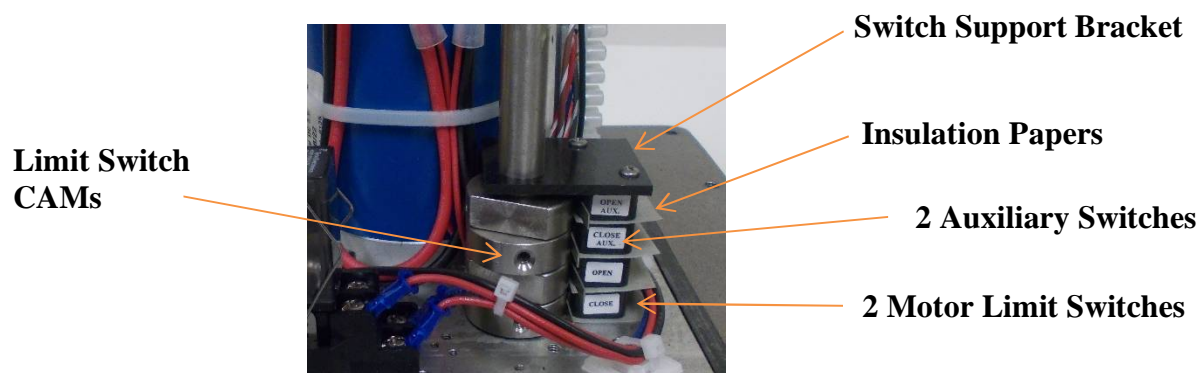

### SNS2000 Series Actuator Auxiliary Switch Location

Most Auxiliary switches are ordered with the unit, but an Auxiliary Switch Kit (#90100-2) can be ordered and installed in the field. Follow the appropriate wiring diagram for electrical connections of the switch wires. On the SNS2000 Series Actuator, the Auxiliary Switches will mount directly on top of the motor limit switches. This kit will include 2 wired switches, longer screws, 2 additional CAMs with set screws, support bracket, insulation papers and a few wire ties.

### Auxiliary Switch Installation

1. Turn off the power supply to actuator.
2. Remove the screws/bolts securing the actuator cover and remove cover.
3. Remove the two (2) 4-40 x 1” long screws securing switches to base or bracket.
4. Stack auxiliary switch(es) on top of existing limit switches putting an insulating paper between each.

5. Install CAM(s) onto shaft, the order does not matter.
  6. Install the black stabilizer bracket on to the shaft stacking it on top of the cams.
- B. Installing (2) auxiliary switches: Secure switches through the stabilizer bracket with 4-40 x 2" long screws.

**Install  
Auxiliary  
Switches**

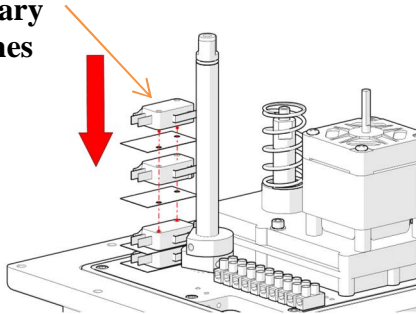

**Stabilizer Bracket and  
2" Long Screws**

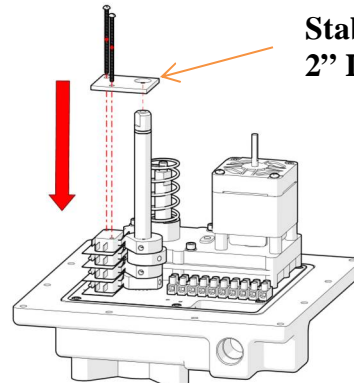

7. ICI standard actuators are shipped with a ten-position terminal strip and are wired for light indication; N.O. contact of the open switch is connected to terminal #4 and N.O. contact on close switch is connected to terminal #5. These two leads must be removed. (**MODULATING ACTUATORS ARE NOT WIRED FOR LIGHT INDICATION, SKIP TO STEP 12**)
8. Loosen terminal connection #4 and pull the yellow wire out of terminal strip. Using wire cutters, cut this yellow wire off back at the limit switch and discard the yellow wire.
9. Loosen terminal connection #5 and pull the orange wire out of terminal strip. Using wire cutters, cut this orange wire off back at the limit switch and discard the orange wire.
10. If there is a Green Ground wire in one of the terminals 4-10, remove this completely.
11. **SWITCH 1:** Connect the common (C) wire (**VIO/WHT**), the normally open (N.O.) wire (**ORG/WHT**), and the normally closed (N.C.) wire (**BLU/WHT**) to the internal side of the white terminal block. Use the most appropriate terminal connection per the wiring diagram for your actuator shown on the next page.
12. **SWITCH 2:** If a second auxiliary switch is being installed, connect the common (C) wire (**GRY/WHT**), the normally open (N.O.) wire (**RED/WHT**) and the normally closed (N.C.) wire (**BRN/WHT**) to the internal side of the white terminal block. Use the most appropriate terminal connection per the wiring diagram for your actuator shown on the next page.
13. Verify that all wires are secured and out of the way of switch levers, cams, and other moving parts. Do not interfere with the gasket or cover alignment and be sure wires will not be crushed when cover is re-installed.

**OPTIONAL HEATERS AND CONDENSATION:**

The SNS 2000 Series Actuator has the Option to have an internal Heater installed when manufactured or later in the field. The Heater Kit (#90030), comes with 2 wires that connect into the SNS 2000 PC Board HEATER Connector – polarity DOES NOT matter. The wires are installed into the Terminal Block, one wire into each terminal, and the screws securely tightened. The Heater is self-regulating and does NOT require a thermostat to regulate the temperature. The Heater mounts to the rear of the PC Board Bracket using 2 - #8 screws. The Heater adds about 20W to the overall power consumption of the Actuator.

It is recommended that a Heater, #25020, be installed in applications where the Actuator is subject to Cold Weather and/or Humid Conditions. The Heater will maintain adequate temperature inside the enclosure for the components in Cold applications. It will also maintain a constant temperature to eliminate Condensation in Humid Environments. **The Heater is NOT ON when the SNS 2000 is running on Battery Power – ONLY when running on Mains Power!**



Self-Regulating Heater #25020

2 Pin Heater Terminal Block

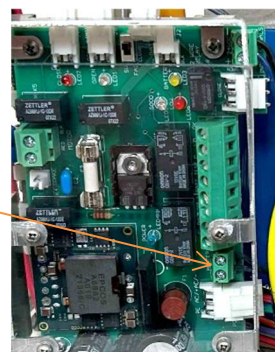

Heater is Mounted on the Back Side of this SNS Board.

**OPTIONAL MECHANICAL BRAKE:**

The SNS 2000 Actuators have the option to be fitted with a 12vdc Spring Applied Power OFF Brake. These can be ordered installed on the actuator, or added to the actuator in the field.

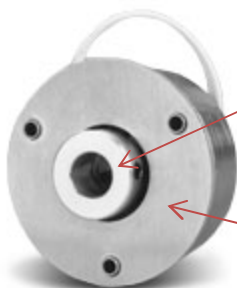

Locking Square Brake Hub Tightens onto Motor Shaft using the set screw.

Brake – Top Side

This brake will Open up to allow the motor shaft to spin freely when the DC power is applied to the motor. When the DC motor power turns OFF, the brake will LOCK the motor shaft in place and keep it from moving and thereby keep the Valve from back driving the Actuator. This is especially helpful in Butterfly Valve & Damper Applications.

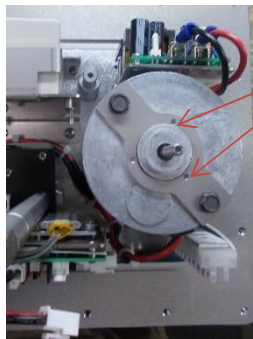

**Motor Without Brake**

**Brake Mounting Bracket with Screw Holes**

**Brake Mounting Screws**

**Locking Brake Hub**

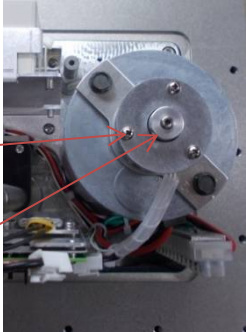

**Motor With Brake**

If installing the DC Brake in the field, the Brake Kit (#90031) will include the needed mounting screws to secure it to the Brake Mounting Bracket (already installed in the Actuator). Slide the Brake Hub over the Motor Shaft & down into the Square Hole in the Brake, but not all the way down – leave some gap. Then, tighten down the Brake Hub Set Screw. The Brake wiring comes with a 2 pin connector installed so the Installer just needs to plug this into the SNS 2000 PC Board Brake Connector, J3.

**Brake Connector plugged into the SNS2000 Board**

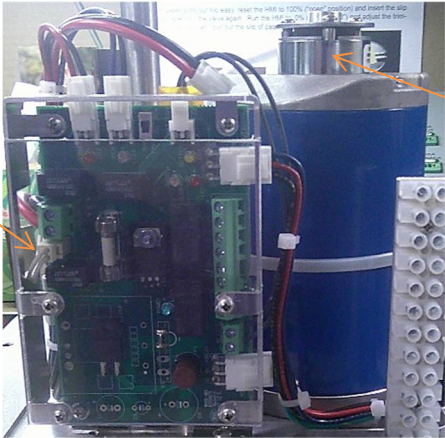

**Power OFF Brake Installed onto Motor**

**DUTY CYCLE:**

All SNS 2000 Series actuators are rated 100% duty cycle at ambient temperature at rated torque.

## NEMA 7 ENCLOSURE, GENERAL:

In general, operation and maintenance of a NEMA 7 electric actuator is no different than that of a NEMA 4 electric actuator. However, there are some precautions that must be followed.

1. **DO NOT** install in ambient temperatures that exceed **140° F**. Mount, Test and Calibrate the actuator on a valve in a non-hazardous location.
2. **DO NOT** under any circumstances **remove the actuator cover** while in a hazardous location when the contacts are still live; this could cause ignition of hazardous atmospheres. After de-energizing the NEMA 7 actuator, wait at least 45 minutes before removing the cover to allow the heater to cool.
3. **DO NOT** under any circumstances **use a NEMA 7 electric actuator in a hazardous location that does not meet the specifications for which the actuator was designed**. The actuator is clearly tagged with the NEMA classification it was designed for.
4. When removing the cover care must be taken not to scratch, scar or deform the flame path of the cover or base of the actuator. This will negate the NEMA 7 rating of the enclosure.
5. When replacing the cover on actuators rated NEMA 4 and 7 take care that the gasket is in place to assure the proper clearance after the cover is secured. After securing the cover screws to the proper torque (see Chart – 132 in/lbs.), check that the clearance between the cover and the base is 0.00” – no gaps!
6. All electrical connections must be to state and local codes and in accordance with the specifications for which the unit is being used.

**NOTE:** *After proper installation, the actuator will require little or no maintenance. In the event maintenance is required remove it from the hazardous location before attempting to work on it. If the actuator is in a critical application and down time is not permitted it is advisable to have a spare actuator in stock.*

If you require Technical Assistance on any of our actuator or control products, please contact your local distributor.

**Indelac Controls, Inc.**  
**6810 Powerline Drive**  
**Florence, KY 41042**  
**+1 (859) 727-7890**

## MANUAL REVISIONS

|               |  |
|---------------|--|
| JUNE 22, 2018 | CHANGED EXTERNAL INDICATOR WIRING CONNECTIONS SECTION – CURRENT LOAD USED TO BE 5A. NEW RELAYS ON BOARD ARE 2A @ 30VDC AND 0.5A @ 125VAC.  |
| MAY 13, 2020  | ADDED ELECTRICAL SPECIFICATIONS FOR AUXILIARY SWITCHES/CONTACT CURRENT; UPDATED INDELAC LOGO.  |
| FEB 3, 2021   | “R1” – NEWLY RE-DESIGNED SNS2000 SERIES W/SMALLER BOARDS AND BATTERY. NEW BRACKET DESIGNS AND LAYOUT TO FIT ALL INTO SINGLE “L” ACTUATOR ENCLSOURE.  |
| SEPT 30, 2021 | MODIFIED OPERATION SECTION INTO STANDARD AND MODULATING. ADDED ADJUSTMENT NOTES TO AUXILIARY SWTICH SECTION. ADDED EXTERNAL CONNECTIONS AND OPERTION SECTION. ENHANCED THE TROUBLESHOOTING SECTION. ADDED BATTERY MAINTENANCE AND CARE SECTION. ADDED THE HEATER AND CONDENSATION SECTION. |
| AUG 14, 2025  | UPDATED WIRING DIAGRAMS TO REFLECT NEW BOARD CHANGES, UPDATED PHOTOS TO SHOW NEW BOARD PLACEMENTS AND MOTOR CHANGE, ADDED TABLE OF CONTENTS, ADDED POSITIONER BOARD CALIBRATION SECTION AND BETTER DESCRIPTIONS OF THE OPTIONS SECTIONS AND HOW THEY WORK.                                 |

## TROUBLESHOOTING

### DC Modulating Board LED Fault Conditions

The Green and Red LEDs on the DC Modulating Board will give the user Fault Status under certain conditions. See the chart below:

| Green | Red   | Condition                      |
|-------|-------|--------------------------------|
| -     | Flash | Limit Switch 1 disconnected    |
| Flash | -     | Limit Switch 2 disconnected    |
| Blink | OFF   | Feedback Pot too Low (<0.25V)  |
| OFF   | Blink | Feedback Pot too High (>4.75V) |
| Blink | Blink | Low Input Voltage (<10V)       |
| ON    | ON    | Input Voltage Too High (>30V)  |

*\*\*Flash = very fast; Blink = longer, slow*

If one of the Limit Switches is **disconnected**, check the jumper wiring to terminals #6-8 and #6-7 on the Modulating board – make sure the wires and terminal screws are tight. (See Modulating Wiring Diagram)

If the Feedback Pot is too **Low** or too **High**, the Actuator is Out of Calibration and the unit needs to be re-calibrated per the above DC Modulating Calibration Steps.

If the Main DC Power to the DC Modulating board drops **below 10vdc** or goes **above 30vdc**, the Fault Condition will be indicated and the Input Power needs to be corrected. Check the voltage from the ProVolt Board to the DC Modulating Board.

**TROUBLESHOOTING**

| <b>SYMPTOM</b>   | <b>PROBLEM</b>  | <b>SOLUTION</b>   |
|--|---|---|
| <b>No Power at the Actuator</b>                        | Mains Power not ON or external Breaker Tripped.                       | Reset external Breaker and Turn ON Mains Power.   |
|  | Blue Power LED not ON.  | Turn ON Mains Power and check the Incoming Power Fuse. May need to Replace the Fuse.    |
|  | Actuator Wired Incorrectly.   | Check ALL Wiring to the Proper Wiring Diagram.  |
| <b>Motor Runs but Output Shaft Does Not Rotate.</b>    | Gear damage or sheared pin/key.                                       | Contact Indelac Controls or nearest Distributor to return for repair.                   |
| <b>Actuator/Valve Oscillates at End of Travel</b>      | Valve Torque too high for Actuator                                    | Install Correct Size Actuator.  |
|  | Actuator mounted to Butterfly Valve and does not have Brake.          | Install Mechanical Brake to Actuator.   |
|  | Motor Brake is out of Adjustment                                      | Adjust Brake and tighten set screw.   |
|  | Set Screw is Loose in Brake Hub.                                      | Re-tighten set screw.   |
| <b>Actuator Does Not Respond to the Control Signal</b> | Blown Input Power Fuse.   | Replace 10A Input Power Fuse, TR5.  |
|  | Blown Motor Fuse.   | Replace 10A Motor Fuse, 5x20mm.   |
|  | Mains Power Not ON.   | Turn ON Mains Power Supply.   |
|  | Actuator Wired Incorrectly.   | Use appropriate Wiring Diagram to Rewire Correctly.                                     |
|  | Incorrect Voltage on Mains Input.                                     | Check Wiring Diagram and Power Supply and make appropriate changes.                     |
|  | Actuator & Valve not Aligned when Actuator was Mounted.               | Remove Actuator and rotate 90 degrees & Re-mount.                                       |
|  | External Voltage Applied to Control Signal Input Terminals.           | Call Indelac Controls to return Actuator for Repair – Circuit will be blown on the PCB. |
|  | Input Signal Wires not tight in Terminals.                            | Tighten Terminal Block Screws.  |
|  | Bad Brake/Locked Up.  | Remove Brake Hub and try to run. If it runs, brake is bad and will need to be replaced. |
| Modulating Signal is Not Present                       | Connect 4-20mA or 0-10v Signal to Actuator. Re-check for Good Signal. |   |

**TROUBLESHOOTING AND FAQ'S (cont.)**

| <b>SYMPTOM</b>   | <b>PROBLEM</b>  | <b>SOLUTION</b>   |
|--|---|---|
| <b>Actuator does NOT go to FAIL position when Mains Power Fails.</b>               | Battery is Dead or Extremely Low.                                   | Check Battery Status LEDs & Re-charge or Replace Battery.                           |
|  | Motor Fuse has Blown.   | Replace 10A Motor Fuse, 5x20mm.   |
|  | Modulating Actuator is set for 0-10v Control Signal.                | Actuator will NOT Fail to OPEN or CLOSE position using 0-10v setting – only 4-20mA. |
|  | Actuator has traveled past the CAM Limits.                          | Reset Limit Switch CAMs.  |
|  | Circuit Blown on the SNS PC Board                                   | Standard SNS 2000 PC Board can be Replaced – Call Indelac Controls for Service.     |
|  | When Mains Power Fails, Check for Yellow Battery Power LED to be ON | If Yellow Battery Power LED is NOT ON, Battery is Dead and needs to be Replaced.    |
| <b>Actuator will Not OPEN or CLOSE Completely</b>                                  | Travel Limits Incorrectly Set                                       | Reset Limit Switch CAMs.  |
|  | Valve Torque too High for Actuator                                  | Install Correct Size Actuator   |
|  | Modulating Actuator Set Points Need Adjustment                      | Adjust the SPAN and ZERO pots on the Modulating Board.                              |
|  | Modulating Actuator is Out of Calibration                           | Re-Calibrate the Actuator with a Good 4-20mA or 0-10v Control Signal.               |
| <b>Red LED to CLOSE or Green LED to OPEN turns ON, but Actuator Does NOT Move.</b> | Blown Motor Fuse  | Replace 10A Motor Fuse, 5x20mm.   |
|  | Blown Circuit on PC Board   | Standard SNS 2000 PC Board can be Replaced – Call Indelac Controls for Service.     |
|  | Limit Switch CAMs Not Set Properly                                  | Reset Limit Switch CAMs so that Switch makes contact for travel.                    |

\*\* If it is suspected that one of the PC Boards in the SNS **Modulating** Actuator is bad, the unit will need to be returned to Indelac for service and re-calibration. This Calibration with the 4-20mA signal can be done in the field, but is complicated and requires a DVM and 4-20mA Loop Calibrator.



# INDELAC

CONTROLS, INC.

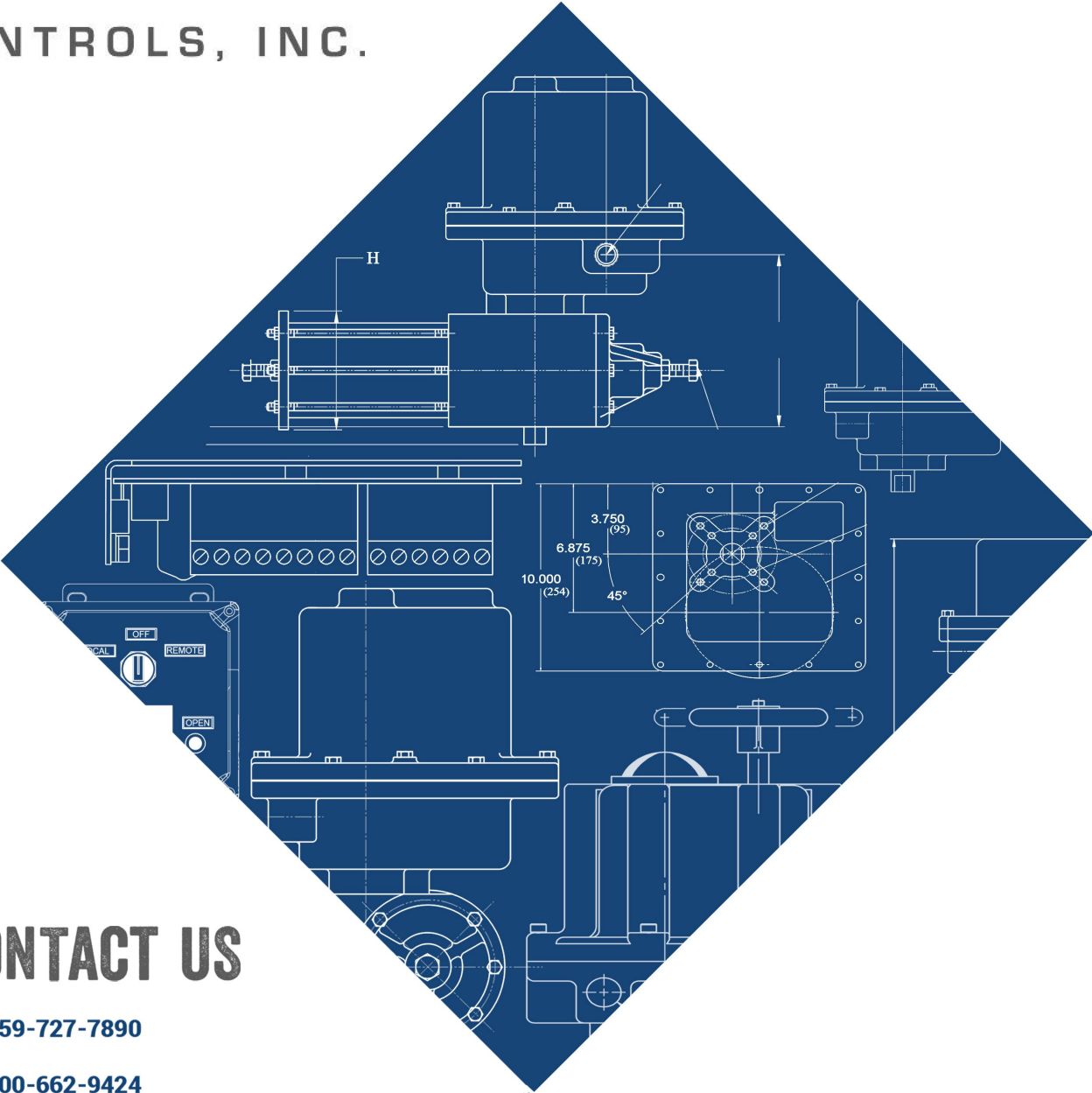

## CONTACT US

 859-727-7890

 800-662-9424

 859-727-4070

 [WWW.INDELAC.COM](http://WWW.INDELAC.COM)

 [SALES@INDELAC.COM](mailto:SALES@INDELAC.COM)